

 **Sealed Air**

**FasFil<sup>®</sup> EZ<sup>™</sup>**

Paper Void-Fill System

**NEW**

# Fast and Easy Void Fill Paper Packaging



# FasFil® EZ™ Paper Void Fill System

Ergonomically designed for quicker and easier packing

## Improve Efficiency, Performance and Sustainability



Sealed Air's innovative new FasFil® EZ™ paper void fill system delivers a solution for individual packing stations. It's perfect for customers who need a packing system that improves performance, productivity, shipping quality — and offers sustainable packaging.

## Smarter, Faster, and Easier

The FasFil® EZ™ system lets your operation run at its best. Simple footswitch operation produces continuous output with the press of a pedal.

The ergonomically designed built-in cutting mechanism allows easy release of paper.



## You will enjoy superior packaging output quality — every day

The FasFil® EZ's™ unique crimping mechanism helps you make more efficient use of packaging materials by producing more cubic metre of void-fill material per square metre of paper used.



## More Choices For Better Results

A variety of options help you improve efficiency by saving time, energy and material:

- The output length control feature delivers customised paper lengths eliminating excess material with each press of the pedal.
- System positioning is flexible. Mount the FasFil® EZ™ on a floor stand or on a table and adjust the system to the height desired. Three different brackets are supplied so the angle of the FasFil® EZ™ system head can be adjusted to suit your packaging operations.
- FasFil® EZ™ paper is made of 100% recycled content.



Paper fibre is 100% renewable, and all production scrap is reclaimed. Material can be recycled in mixed paper streams.

Sealed Air Sustainability

## Specifications

### Electrical:

200-240 VAC, 50 Hz,  
Single Phase, 13A

### Weight (without roll):

Floor Stand: 33 kg  
Tabletop Stand: 25.5 kg

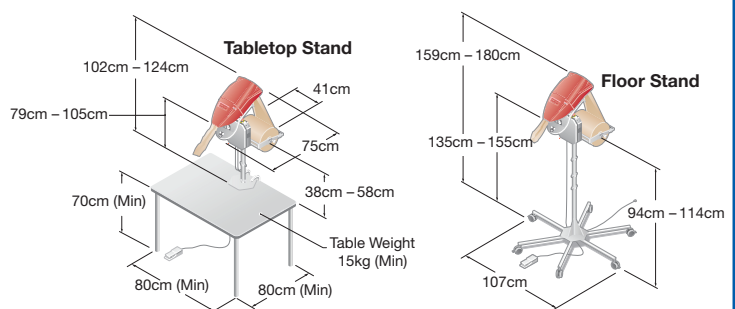

Distributed by:

FFEZ-GB-09-11



## Protective Packaging

Telford Way, Kettering NN16 8UN  
United Kingdom

+44 1536 315700 Fax: +44 1536 410576

Email: PPDeuromktg@sealedair.com

www.sealedair-emea.com

Our Products Protect Your Products®

Corporate office: Sealed Air Corporation,  
200 Riverfront Boulevard, Elmwood Park, NJ 07407, USA  
www.sealedair.com

Sealed Air has companies throughout the world.

© Sealed Air Corporation 2011. All rights reserved.

