

CONCRETE SCREW

PRODUCT DATA SHEET

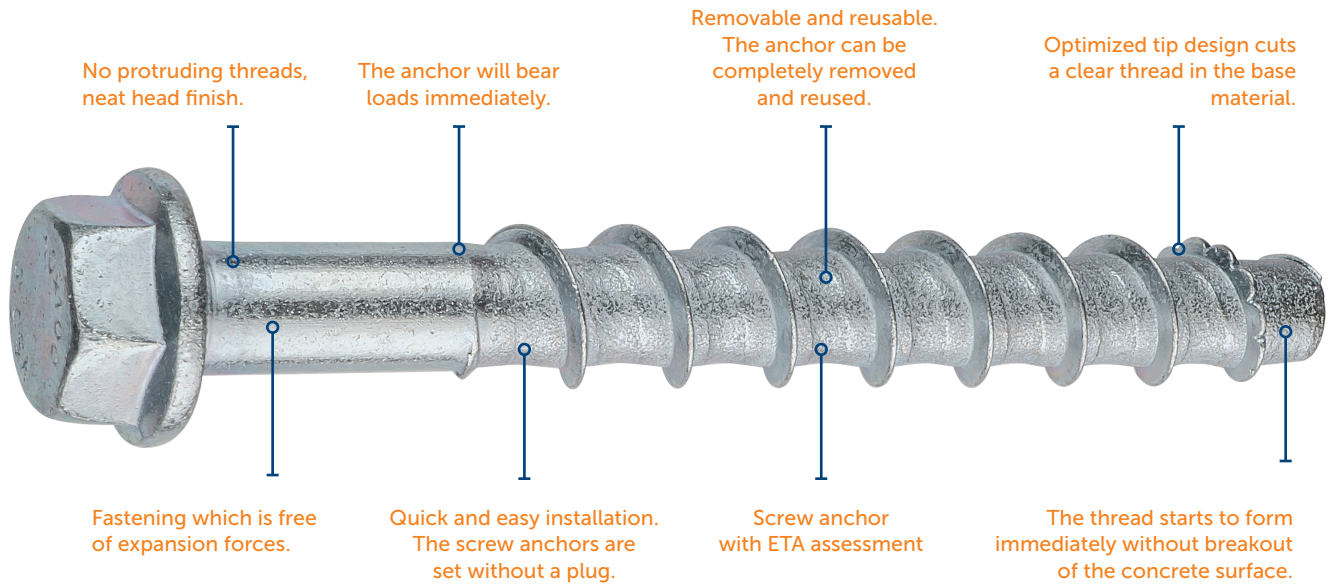

ETA-ASSESSED, HIGH PERFORMANCE CONCRETE SCREWS FROM FINLAND



CONCRETE SCREWS S-CSA+

The S-CSA+ concrete screws are very easy and quick to install. Requires neither additional tools nor operations. It is able to take high loads even with relatively small spacings and edge distances. It is removable and reusable and therefore fits also well for temporary fixings.

Description

- Self-tapping, approved screw anchors for push-through installations.
- No expansion forces allowing for relatively small edge distances and spacings.
- ZP (zinc electro plated) for dry indoor use.
- ML (Multi Layer) corrosion protection coating tested 2016 hours in SST acc. ISO 9227 and then fulfills the requirements for the neutral salt spray test with the corrosion class "C3 very high" according to DIN EN ISO 12944-6:2018-06.
- A4 Stainless Steel with hardened carbon steel tip, coated
- Combines the benefits of undercut and chemical anchors requiring neither additional tools and operations nor hardening time.
- The concrete screw is installed directly through the fixture into the bore hole only by screwing. By doing so, the thread is cutting itself into the concrete and that way creating a mechanical interlock over the total anchorage depth.

BASE MATERIALS

Approved for



Cracked concrete



Uncracked concrete



Hollow concrete slab

Also suitable for



Solid clay brick



Solid sand-lime brick

TYPES

S-CSA+ HEX

Concrete screw with hexagonal head and flange. Sizes 8, 10, 14.

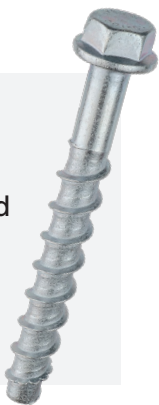

S-CSA+ HEX

Concrete screw with hexagonal head and flange. Sizes 5, 6. Size 5 without T-drive.



S-CSA+ HEX WOF

Concrete screw with hexagonal head without flange. Size 14.



S-CSA+ CS

Concrete screw with countersunk head and T-drive. Sizes 5, 6, 8, 10.

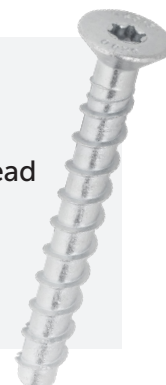

S-CSA+ P (FL)

Concrete screw with flat panhead. Size 6.



S-CSA+ P

Concrete screw with pan head and T-drive. Size 6.



S-CSA+ I

Concrete screw with combined internal thread M8 / M10. Size 6.



S-CSA+ E

Concrete screw with external thread M8. Size 6.









S-CSA A4

Stainless steel concrete screws, sizes 6, 8 and 10.

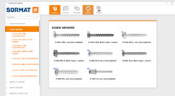

ASSESSMENTS / CERTIFICATIONS / APPLICATIONS

| Description of document | Authority/ Laboratory | ID | Additional info |
|---|--|---|--|
| European Technical Assessment  | ZAG -National Building and Civil Engineering Institute, Slovenia | ETA-20/0446 (S-CSA+ 6, 8, 10, 14) | EAD 330232-02-0601, Option 1 |
| European Technical Assessment  | ZAG -National Building and Civil Engineering Institute, Slovenia | ETA-17/1009 (S-CSA+, S-CSA A4) | Concrete screw of size 6 for multiple use in non-structural applications, EAD 330747-00-0601, (Part 6) |
| European Technical Assessment  | ZAG -National Building and Civil Engineering Institute, Slovenia | ETA-22/0413 (S-CSA A4) | EAD 330232-01-0601, Option 1 |
| General construction technique permit DIBt  | DIBt | Z-21.8-2136 | S-CSA+ 10 & 14 mm for temporary fastenings in concrete |
| Seismic resistance  | ZAG -National Building and Civil Engineering Institute, Slovenia | ETA-20/0446 (S-CSA+ 6, 8, 10, 14) | EN 1992-4 |
| Fire resistance  | ZAG -National Building and Civil Engineering Institute, Slovenia | ETA-20/0446 ETA-17/1009 ETA-22/0413 | EN 1992-4 |
| YouTube installation videos  | EJOT Sormat Oy | | Sormat Concrete screw installation video |
| Sormat Trustfix anchor calculation software  | Sormat Oy / S&P Software Consulting | | TrustFIX anchor calculation |
| CAD-blocks for AutoCAD  | EJOT Sormat Oy | | Blocks installation instructions for AutoCAD |
| ProdLib  | ProdLib Oy | prodlib.com/library/sormat | CAD block library |

Additional information concerning all given data in the product data sheet

- Load figures include the partial safety factors as per assessments and a partial safety factor on the action of $\gamma_f = 1.4$. Load figures apply for a rebar spacing $s \geq 15$ cm or alternatively for a rebar spacing $s \geq 10$ cm in combination with a rebar diameter of $d_s \leq 10$ mm.
- If spacings or edge distances become smaller than the characteristic figures ($s_{cr,N} / c_{cr,N}$) a calculation as per EN 1992-4 needs to be carried out. For more details, see ETA-20/0446, ETA-17/1009 and ETA-22/0413.
- Concrete is considered uncracked when the value of tension within the concrete is $\sigma_L + \sigma_R \leq 0$. In the absence of detailed verification $\sigma_R = 3$ N/mm² can be assumed (σ_L equals the tension within the concrete as a result of external loads, forces on anchor included; σ_R equals the tension coming from shrinkage or creep of the concrete, as well as displacements of supports or temperature variations).
- Shear load figures apply for an anchor without influence of a concrete edge. For shear loads close to an edge ($c \leq 10 \times h_{ef}$), concrete edge failure has to be checked as per EN 1992-4.

STATIC AND QUASI-STATIC LOADS S-CSA+

The data of these tables is based on:

- Material cold forged carbon steel
- Concrete C20/25, $f_{ck,cube} = 25 \text{ N/mm}^2$.
- Installation has been done correctly.
- No influence of edge distances and spacings (see page 19).
- Respect of minimum base material thickness (see page 19).

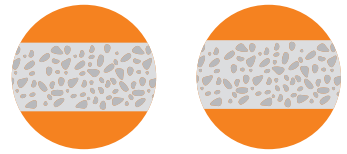

Characteristic resistances

| | S-CSA 5 | | S-CSA+ 6 | | | | S-CSA+ 8 | | S-CSA+ 10 | | | S-CSA+ 14 | | |
|---|---------|------|----------|--------|-------|-------|----------|-------|-----------|-------|-------|-----------|-------|-------|
| | - | - | PART 6 | PART 6 | OPT 1 | OPT 1 | OPT 1 | OPT 1 | OPT 1 | OPT 1 | OPT 1 | OPT 1 | OPT 1 | OPT 1 |
| Effective anchorage depth h_{ef} [mm] | 19,0 | 27,5 | 27,6 | 31,9 | 29,8 | 42,5 | 39,2 | 51,9 | 42,5 | 55,3 | 68,0 | 49,3 | 66,3 | 91,8 |
| Nominal anchorage depth h_{nom} [mm] | 35 | 45 | 35 | 40 | 40 | 55 | 50 | 65 | 55 | 70 | 85 | 65 | 85 | 115 |

Uncracked concrete

| | | | | | | | | | | | | | | |
|-----------------------|-----|-----|------|------|------|------|-------|-------|-------|-------|-------|------|-------|-------|
| Tension N_{Rk} [kN] | 2,4 | 3,5 | 4,0 | 4,0 | 7,0 | 9,7 | 12,1 | 18,4 | 13,6 | 20,2 | 27,6 | 15,8 | 26,6 | 43,3 |
| Shear V_{Rk} [kN] | 2,4 | 3,5 | 9,4* | 9,4* | 9,4* | 9,4* | 19,1* | 19,1* | 31,8* | 31,8* | 31,8* | 56,2 | 61,1* | 61,1* |

Cracked concrete

| | | | | | | | | | | | | | | |
|-----------------------|----|----|------|------|------|------|-------|-------|------|-------|-------|------|------|-------|
| Tension N_{Rk} [kN] | NA | NA | 4,0 | 4,0 | 3,5 | 4,8 | 6,8 | 12,5 | 7,9 | 10,3 | 19,3 | 9,0 | 16,6 | 30,2 |
| Shear V_{Rk} [kN] | NA | NA | 9,4* | 9,4* | 9,4* | 9,4* | 19,1* | 19,1* | 28,6 | 31,8* | 31,8* | 39,3 | 61,3 | 61,1* |

* Failure mode = steel

Design resistances

| | S-CSA 5 | | S-CSA+ 6 | | | | S-CSA+ 8 | | S-CSA+ 10 | | | S-CSA+ 14 | | |
|---|---------|------|----------|--------|-------|-------|----------|-------|-----------|-------|-------|-----------|-------|-------|
| | - | - | PART 6 | PART 6 | OPT 1 | OPT 1 | OPT 1 | OPT 1 | OPT 1 | OPT 1 | OPT 1 | OPT 1 | OPT 1 | OPT 1 |
| Effective anchorage depth h_{ef} [mm] | 19,0 | 27,5 | 27,6 | 31,9 | 29,8 | 42,5 | 39,2 | 51,9 | 42,5 | 55,3 | 68,0 | 49,3 | 66,3 | 91,8 |
| Nominal anchorage depth h_{nom} [mm] | 35 | 45 | 35 | 40 | 40 | 55 | 50 | 65 | 55 | 70 | 85 | 65 | 85 | 115 |

Uncracked concrete

| | | | | | | | | | | | | | | |
|-----------------------|-----|-----|------|------|------|------|-------|-------|-------|-------|-------|------|-------|-------|
| Tension N_{Rd} [kN] | 1,6 | 2,3 | 2,7 | 2,7 | 4,7 | 6,5 | 8,0 | 12,3 | 9,1 | 13,5 | 18,4 | 10,5 | 17,7 | 28,8 |
| Shear V_{Rd} [kN] | 1,6 | 2,3 | 7,5* | 7,5* | 7,5* | 7,5* | 15,3* | 15,3* | 25,4* | 25,4* | 25,4* | 37,5 | 48,9* | 48,9* |

Cracked concrete

| | | | | | | | | | | | | | | |
|-----------------------|----|----|------|------|------|------|-------|-------|------|-------|-------|------|------|-------|
| Tension N_{Rd} [kN] | NA | NA | 2,7 | 2,7 | 2,3 | 3,2 | 4,5 | 8,3 | 5,3 | 6,9 | 12,9 | 6 | 11,1 | 20,1 |
| Shear V_{Rd} [kN] | NA | NA | 7,5* | 7,5* | 7,5* | 7,5* | 15,3* | 15,3* | 19,1 | 25,4* | 25,4* | 26,2 | 40,9 | 48,9* |

* Failure mode = steel

Recommended loads

| | S-CSA 5 | | S-CSA+ 6 | | | | S-CSA+ 8 | | S-CSA+ 10 | | | S-CSA+ 14 | | |
|---|---------|------|----------|--------|-------|-------|----------|-------|-----------|-------|-------|-----------|-------|-------|
| | - | - | PART 6 | PART 6 | OPT 1 | OPT 1 | OPT 1 | OPT 1 | OPT 1 | OPT 1 | OPT 1 | OPT 1 | OPT 1 | OPT 1 |
| Effective anchorage depth h_{ef} [mm] | 19,0 | 27,5 | 27,6 | 31,9 | 29,8 | 42,5 | 39,2 | 51,9 | 42,5 | 55,3 | 68,0 | 49,3 | 66,3 | 91,8 |
| Nominal anchorage depth h_{nom} [mm] | 35 | 45 | 35 | 40 | 40 | 55 | 50 | 65 | 55 | 70 | 85 | 65 | 85 | 115 |

Uncracked concrete

| | | | | | | | | | | | | | | |
|------------------------|-----|-----|------|------|------|------|-------|-------|-------|-------|-------|------|-------|-------|
| Tension N_{Rec} [kN] | 1,1 | 1,7 | 1,9 | 1,9 | 3,3 | 4,6 | 5,7 | 8,8 | 6,5 | 9,6 | 13,1 | 7,5 | 12,6 | 20,6 |
| Shear V_{Rec} [kN] | 1,1 | 1,7 | 5,4* | 5,4* | 5,4* | 5,4* | 10,9* | 10,9* | 18,2* | 18,2* | 18,2* | 26,8 | 34,9* | 34,9* |

Cracked concrete

| | | | | | | | | | | | | | | |
|------------------------|----|----|------|------|------|------|-------|-------|------|-------|-------|------|------|-------|
| Tension N_{Rec} [kN] | NA | NA | 1,9 | 1,9 | 1,7 | 2,3 | 3,2 | 6 | 3,8 | 4,9 | 9,2 | 4,3 | 7,9 | 14,4 |
| Shear V_{Rec} [kN] | NA | NA | 5,4* | 5,4* | 5,4* | 5,4* | 10,9* | 10,9* | 13,6 | 18,2* | 18,2* | 18,7 | 29,2 | 34,9* |

* Failure mode = steel

STATIC AND QUASI-STATIC LOADS S-CSA A4

The data of these tables is based on:

- Material cold forged stainless steel A4, hardened steel tip
- Concrete C20/25, $f_{ck,cube} = 25 \text{ N/mm}^2$.
- Installation has been done correctly.
- No influence of edge distances and spacings (see page 20).
- Respect of minimum base material thickness (see page 20).

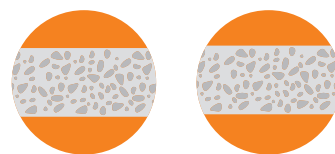

Characteristic resistances

| | | | S-CSA A4 6 | | | S-CSA A4 8 | | S-CSA A4 10 | |
|------------------------------------|------------------|------|------------|-------|-------|------------|-------|-------------|-------|
| | | | PART 6 | OPT 1 | | OPT 1 | | OPT 1 | |
| Effective anchorage depth h_{ef} | [mm] | | 31,9 | 34,0 | 42,5 | 35,8 | 48,5 | 39,1 | 64,6 |
| Nominal anchorage depth h_{nom} | [mm] | | 40 | 45 | 55 | 50 | 65 | 55 | 85 |
| Uncracked concrete | Tension N_{Rk} | [kN] | 6,0 | 6,0 | 9,5 | 8,5 | 16,6 | 11,0 | 25,4 |
| | Shear V_{Rk} | [kN] | 13,4* | 14,3* | 14,3* | 24,3* | 24,3* | 29,4* | 29,4* |
| Cracked concrete | Tension N_{Rk} | [kN] | 6,0 | 2,5 | 3,5 | 3,0 | 8,5 | 2,5 | 9,0 |
| | Shear V_{Rk} | [kN] | 12,4 | 14,3* | 14,3* | 24,3* | 24,3* | 29,4* | 29,4* |

* Failure mode = steel

Design resistances

| | | | S-CSA A4 6 | | | S-CSA A4 8 | | S-CSA A4 10 | |
|------------------------------------|------------------|------|------------|-------|------|------------|-------|-------------|-------|
| | | | PART 6 | OPT 1 | | OPT 1 | | OPT 1 | |
| Effective anchorage depth h_{ef} | [mm] | | 31,9 | 34,0 | 42,5 | 35,8 | 48,5 | 39,1 | 64,6 |
| Nominal anchorage depth h_{nom} | [mm] | | 40 | 45 | 55 | 50 | 65 | 55 | 85 |
| Uncracked concrete | Tension N_{Rd} | [kN] | 4,0 | 4,0 | 6,3 | 5,7 | 11,1 | 7,3 | 16,9 |
| | Shear V_{Rd} | [kN] | 8,9* | 9,5* | 9,5* | 16,2* | 16,2* | 19,6* | 19,6* |
| Cracked concrete | Tension N_{Rd} | [kN] | 4,0 | 1,7 | 2,3 | 2,0 | 5,7 | 1,7 | 6,0 |
| | Shear V_{Rd} | [kN] | 8,3 | 9,5* | 9,5* | 14,3 | 16,2* | 18,5 | 19,6 |

* Failure mode = steel

Recommended loads

| | | | S-CSA A4 6 | | | S-CSA A4 8 | | S-CSA A4 10 | |
|------------------------------------|-------------------|------|------------|-------|------|------------|-------|-------------|-------|
| | | | PART 6 | OPT 1 | | OPT 1 | | OPT 1 | |
| Effective anchorage depth h_{ef} | [mm] | | 31,9 | 34,0 | 42,5 | 35,8 | 48,5 | 39,1 | 64,6 |
| Nominal anchorage depth h_{nom} | [mm] | | 40 | 45 | 55 | 50 | 65 | 55 | 85 |
| Uncracked concrete | | | | | | | | | |
| Uncracked concrete | Tension N_{Rec} | [kN] | 2,9 | 2,9 | 4,5 | 4,0 | 7,9 | 5,2 | 12,1 |
| | Shear V_{Rec} | [kN] | 6,4* | 6,8* | 6,8* | 11,6* | 11,6* | 14,0* | 14,0* |
| Cracked concrete | | | | | | | | | |
| Cracked concrete | Tension N_{Rec} | [kN] | 2,9 | 1,2 | 1,7 | 1,4 | 4,0 | 1,2 | 4,3 |
| | Shear V_{Rec} | [kN] | 5,9 | 6,8* | 6,8* | 10,2 | 11,6* | 13,2 | 14,0* |

* Failure mode = steel

The partial safety factor for action is $\gamma = 1.4$.

BASIC LOADING DATA FOR PRECAST PRE-STRESSED HOLLOW CORE SLABS

The data of these tables is based on:

- Concrete C30/37 to C50/60
- Installation has been done correctly.
- The data of these tables is based on ETA-17/1009 (S-CSA+ 6, S-CSA A4 6).

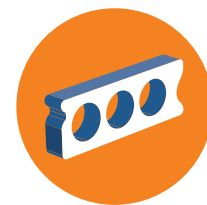

Characteristic resistances

| | | | S-CSA+ 6 | (S-CSA A4 6) | |
|--------------------------|--------------------|------|--------------|--------------|-----------|
| Nominal anchorage depth | h_{nom} | [mm] | 35 / 40 (40) | | |
| Flange thickness | d_b | [mm] | ≥ 25 | ≥ 30 | ≥ 40 |
| Load for all directions | F_{Rk} | [kN] | 2,5 (2,0) | 3,5 (3,0) | 5,0 (5,5) |
| Char. bending resistance | $M_{Rk,s}^0$ | [Nm] | 16,0 | | |
| Edge distance | $c_{cr} = c_{min}$ | [mm] | 100 | | |
| Spacing | $s_{cr} = s_{min}$ | [mm] | 100 | | |

Design resistances

| | | | S-CSA+ 6 | (S-CSA A4 6) | |
|---------------------------|--------------------|------|--------------|--------------|-----------|
| Nominal anchorage depth | h_{nom} | [mm] | 35 / 40 (40) | | |
| Flange thickness | d_b | [mm] | ≥ 25 | ≥ 30 | ≥ 40 |
| Load for all directions | F_{Rd} | [kN] | 1,7 (1,3) | 2,3 (2) | 3,3 (3,7) |
| Design bending resistance | $M_{Rd,s}$ | [Nm] | 12,8 | | |
| Edge distance | $c_{cr} = c_{min}$ | [mm] | 100 | | |
| Spacing | $s_{cr} = s_{min}$ | [mm] | 100 | | |

Recommended loads

| | | | S-CSA+ 6 | (S-CSA A4 6) | |
|-------------------------|--------------------|------|--------------|--------------|-----------|
| Nominal anchorage depth | h_{nom} | [mm] | 35 / 40 (40) | | |
| Flange thickness | d_b | [mm] | ≥ 25 | ≥ 30 | ≥ 40 |
| Load for all directions | F_{rec} | [kN] | 1,2 (1,0) | 1,7 (1,4) | 2,4 (2,6) |
| Rec. bending load | M_{rec} | [Nm] | 9,1 | | |
| Edge distance | $c_{cr} = c_{min}$ | [mm] | 100 | | |
| Spacing | $s_{cr} = s_{min}$ | [mm] | 100 | | |

The partial safety factor for action is $\gamma = 1.4$.

Requirements for multiple anchoring

The definition of redundant fastening according to Member States is given in the EAD 330747 § 1.2.1. In Absence of definition by Member State the following default values may be taken.

| Minimum number of fixing points | Minimum number of anchors per fixing point | Maximum design load of action N_{sd} per fixing point |
|---------------------------------|--|---|
| 3 | 1 | 2 kN |
| 4 | 1 | 3 kN |

The value N_{sd} might be increased if in the design it is shown that the requirements on the strength and stiffness of the fixture in the serviceability and ultimate states after the failure of one anchor are fulfilled.

INSTALLATION INSTRUCTIONS IN PRE-STRESSED HOLLOW CORE SLABS

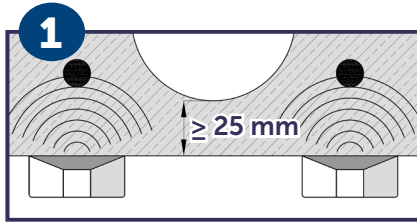

1. Locate rebars by means of suitable detector

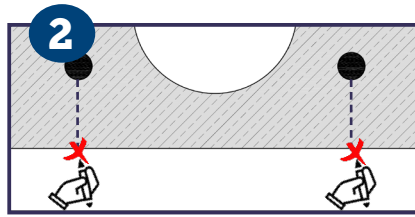

2. Mark rebar location

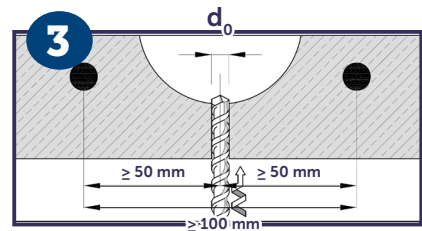

3. Make a cylindrical hole

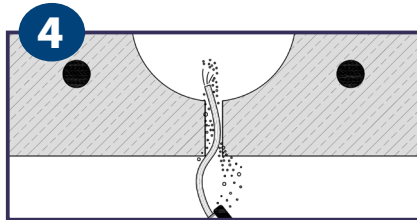

4. Clean the hole

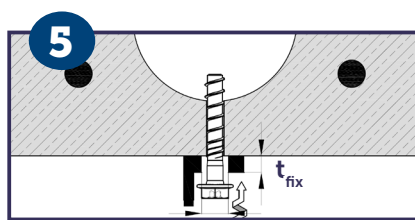

5. Install the screw anchor very gently by screwdriver or torque wrench. Avoid overtightening.

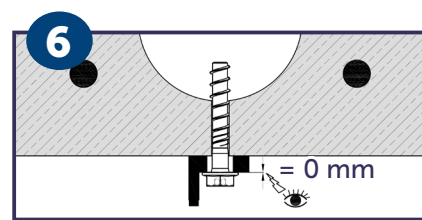

6. Ensure that the screw anchor head fully rests without any gap on the fixture and is not damaged

Admissible anchor position in pre-stressed hollow core slabs

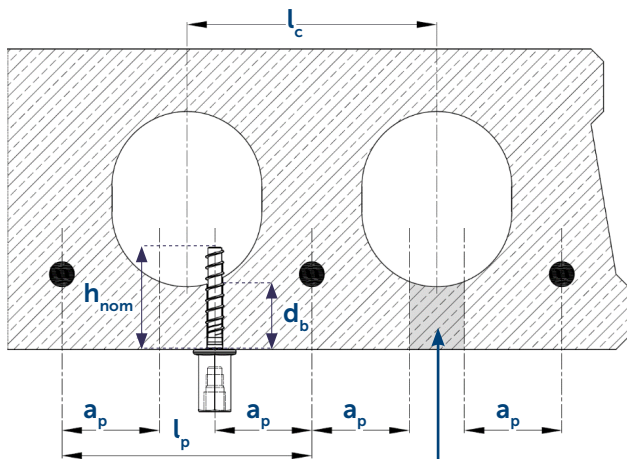

Admissible anchor position

Core distance $l_c \geq 100 \text{ mm}$

Pre-stressing steel distance $l_p \geq 100 \text{ mm}$

Distance between anchor position and prestressing steel $a_p \geq 50 \text{ mm}$

Minimum spacing and edge distance of anchors and distance between anchor groups in pre-stressed hollow core slabs

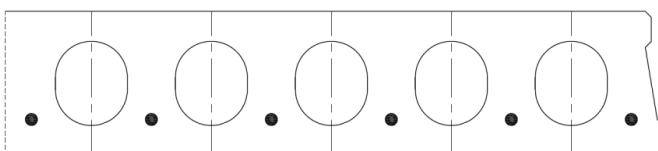

Minimum edge distance $c_{\min} \geq 100 \text{ mm}$

Minimum anchor spacing $s_{\min} \geq 100 \text{ mm}$

Minimum distance between anchor groups $a_{\min} \geq 100 \text{ mm}$

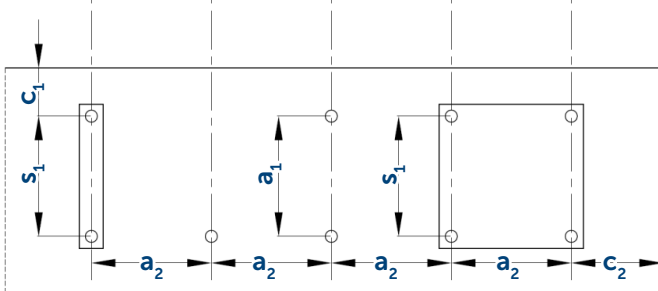

c1, c2 edge distance
s1, s2 anchor spacing
a1, a2 distance between anchor groups

BASIC LOADING DATA FOR PRECAST PRE-STRESSED HOLLOW CORE SLABS S-CSA+ 14

The data of these tables is based on:

- Concrete C30/37 to C50/60 (uncracked)
- Installation has been done correctly.
- No edge distance and spacing influence
- For single anchor
- For temporary application
- Prior to every reuse, the wear of the thread shall be verified with an appropriate checking gauge (CG+)
- Ratio core width/web thickness $\leq 5,3$

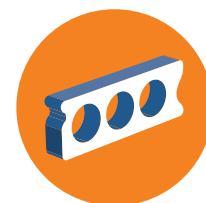

Installation position for temporary fastening in hollow core slab:

- Top position of the slab is allowed.
- Anchor to be installed within position of ± 10 mm of the thickest section of the solid part.

Design resistances: Concrete C30/37

| | | | S-CSA+ | | |
|-------------------------|-----------|------|--------|------|------|
| | | | 14 | | |
| Nominal anchorage depth | h_{nom} | (mm) | 65 | 85 | 115 |
| Drill hole depth | $h1 \geq$ | (mm) | 75 | 95 | 125 |
| Tension | N_{Rd} | (kN) | 12,4 | 19,7 | 29,5 |
| Shear | V_{Rd} | (kN) | 13,9 | 21,7 | 29,4 |

Recommended loads: Concrete C30/37

| | | | S-CSA + | | |
|-------------------------|-----------|------|---------|------|------|
| | | | 14 | | |
| Nominal anchorage depth | h_{nom} | (mm) | 65 | 85 | 115 |
| Drill hole depth | $h1 \geq$ | (mm) | 75 | 95 | 125 |
| Tension | N_{Rec} | (kN) | 8,9 | 14,1 | 21,0 |
| Shear | V_{Rec} | (kN) | 9,9 | 15,5 | 21,0 |

Design resistances: Concrete C50/60

| | | | S-CSA+ | | |
|-------------------------|-----------|------|--------|------|------|
| | | | 14 | | |
| Nominal anchorage depth | h_{nom} | (mm) | 65 | 85 | 115 |
| Drill hole depth | $h1 \geq$ | (mm) | 75 | 95 | 125 |
| Tension | N_{Rd} | (kN) | 15,3 | 22,6 | 39,4 |
| Shear | V_{Rd} | (kN) | 17,9 | 28,0 | 38,0 |

Recommended loads: Concrete C50/60

| | | | S-CSA + | | |
|-------------------------|-----------|------|---------|------|------|
| | | | 14 | | |
| Nominal anchorage depth | h_{nom} | (mm) | 65 | 85 | 115 |
| Drill hole depth | $h1 \geq$ | (mm) | 75 | 95 | 125 |
| Tension | N_{Rec} | (kN) | 10,9 | 16,1 | 28,1 |
| Shear | V_{Rec} | (kN) | 12,8 | 20,0 | 27,1 |

INSTALLATION INSTRUCTIONS IN PRE-STRESSED HOLLOW CORE SLABS S-CSA+ 14

Anchor spacing and edge distances

| | | | S-CSA+ | | |
|--|--|--|--------|--|--|
| | | | 14 | | |

| | | | | | |
|------------------------------|-----------|------|--------------|----|-----|
| Nominal anchorage depth | h_{nom} | (mm) | 65 | 85 | 115 |
| Minimum spacing | s_{min} | (mm) | 60 | | |
| Minimum edge distance | c_{min} | (mm) | 60 | | |
| Characteristic spacing | s_{cr} | (mm) | $3 h_{ef}$ | | |
| Characteristic edge distance | c_{cr} | (mm) | $1,5 h_{ef}$ | | |

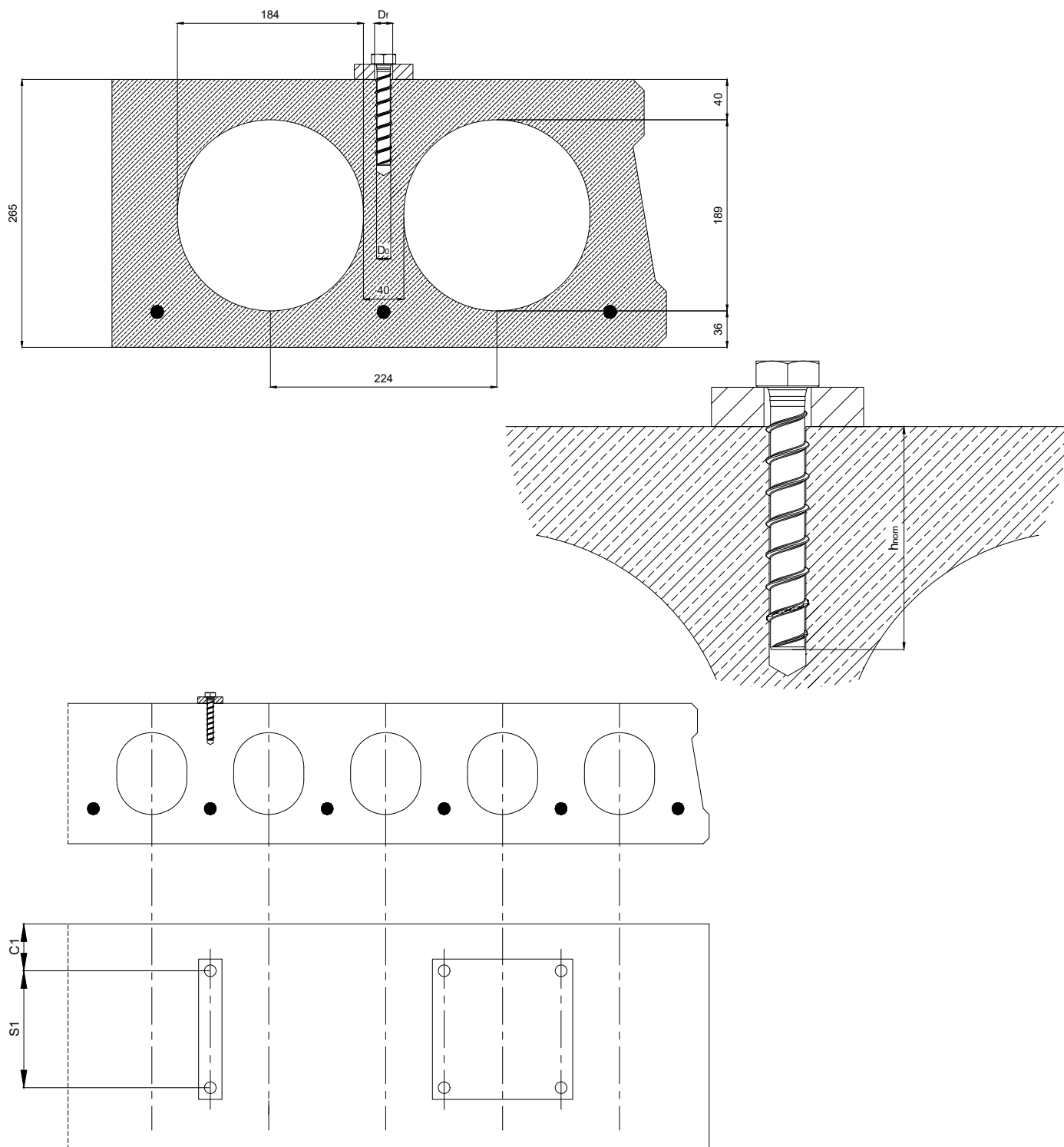

SEISMIC RESISTANCE

Design acc. EN 1992-4 Performance category C1



The data of these tables is based on:

- Concrete C20/25, $f_{ck,cube} = 25 \text{ N/mm}^2$
- Installation has been done correctly
- No influence of edge distances and spacings
- Respect of minimum base material thickness
- $\alpha_{gap} = 0,5$ (used without seismic filling washer, concerns only the shear values)
- ETA-20/0446 (S-CSA+)

Characteristic resistances

| Anchor size | | 6-2 | 8-2 | 10-3 | 14-3 |
|------------------------------------|------|-------------|-------------|-------------|--------------|
| Effective anchorage depth h_{ef} | [mm] | 42,5 | 51,9 | 68,0 | 91,8 |
| Cracked concrete | | | | | |
| Tension $N_{Rk, seis}$ | [kN] | 4,8 | 10,9 | 16,4 | 25,7 |
| Shear $V_{Rk, seis}$ | [kN] | 3,7* | 6,5* | 9,7* | 26,0* |

Design resistances

| Anchor size | | 6-2 | 8-2 | 10-3 | 14-3 |
|------------------------------------|------|-------------|-------------|-------------|--------------|
| Effective anchorage depth h_{ef} | [mm] | 42,5 | 51,9 | 68,0 | 91,8 |
| Cracked concrete | | | | | |
| Tension $N_{Rd, seis}$ | [kN] | 3,2 | 7,3 | 10,9 | 17,2 |
| Shear $V_{Rd, seis}$ | [kN] | 3,0* | 5,2* | 7,8* | 20,8* |

Recommended loads

| Anchor size | | 6-2 | 8-2 | 10-3 | 14-3 |
|------------------------------------|------|-------------|-------------|-------------|--------------|
| Effective anchorage depth h_{ef} | [mm] | 42,5 | 51,9 | 68,0 | 91,8 |
| Cracked concrete | | | | | |
| Tension $N_{Rec, seis}$ | [kN] | 2,3 | 5,2 | 7,8 | 12,3 |
| Shear $V_{Rec, seis}$ | [kN] | 2,1* | 3,7* | 5,5* | 14,8* |

α_{seis} and α_{gap} included as per EOTA TR 045. The values don't consider any filling of the annular gap between the anchor and the fixture.

* Failure mode = steel

SEISMIC RESISTANCE

Design acc. EN 1992-4 Performance category C2



The data of these tables is based on:

- Concrete C20/25, $f_{ck,cube} = 25 \text{ N/mm}^2$
- Installation has been done correctly
- No influence of edge distances and spacings
- Respect of minimum base material thickness
- $\alpha_{gap} = 1,0$ (used with seismic filling washer, concerns only the shear values)
- ETA-20/0446 (S-CSA+)

Characteristic resistances

| Anchor size | | 8-2 | 10-3 | 14-3 |
|------------------------------------|------|--------------|--------------|--------------|
| Effective anchorage depth h_{ef} | [mm] | 51,9 | 68,0 | 91,8 |
| Cracked concrete | | | | |
| Tension $N_{Rk, seis}$ | [kN] | 1,9 | 3,8 | 6,9 |
| Shear $V_{Rk, seis}$ | [kN] | 13,6* | 24,6* | 41,5* |

Design resistances

| Anchor size | | 8-2 | 10-3 | 14-3 |
|------------------------------------|------|--------------|--------------|--------------|
| Effective anchorage depth h_{ef} | [mm] | 51,9 | 68,0 | 91,8 |
| Cracked concrete | | | | |
| Tension $N_{Rd, seis}$ | [kN] | 1,3 | 2,5 | 4,6 |
| Shear $V_{Rd, seis}$ | [kN] | 10,9* | 19,7* | 33,2* |

Recommended loads

| Anchor size | | 8-2 | 10-3 | 14-3 |
|------------------------------------|------|-------------|--------------|--------------|
| Effective anchorage depth h_{ef} | [mm] | 51,9 | 68,0 | 91,8 |
| Cracked concrete | | | | |
| Tension $N_{Rec, seis}$ | [kN] | 0,9 | 1,8 | 3,3 |
| Shear $V_{Rec, seis}$ | [kN] | 7,8* | 14,1* | 23,7* |

α_{seis} and α_{gap} included as per EN 1992-4. The shear values consider filling of the annular gap between the anchor and the fixture.

* Failure mode = steel

FILLING WASHER

For seismic applications

Installation with S-CSA+ concrete screw



When selecting a S-CSA+ concrete screw, please note that the use of the Filling Washer reduces the fixture thickness t_{fix} of the concrete screw



1.

1. Mount matching Filling Washer additionally to Concrete Screw



2.

2. Drive in Concrete Screw with Filling Washer until the anchorage depth h_{nom} is reached



3.

3. Stick mixer reducer tip on static mixer nozzle. Adhesive tape can be used if necessary.



4.

4. Fill the annular gap between Concrete screw and fixture through the hole of the Filling Washer until resin leaks out of this hole.

Please observe installation instructions of injection resin. Load may only be applied after the curing time of the injection resin is reached.

Filling Washer is used for filling the gap between fixture and concrete screw after it has been set.

After installation, Sormat injection resin is injected using the mixer reducer tip (included) until resin seeps out.

| S-CSA+ concrete screw | 8 | 10 | 14 |
|--|--------------------------|--------------------------|--------------------------|
| Filling washer size | 26x12x5 | 28x14x5 | 34x17x5 |
| Reduction of fixture thickness t_{fix} | $t_{fix} - 5 \text{ mm}$ | $t_{fix} - 5 \text{ mm}$ | $t_{fix} - 5 \text{ mm}$ |

FIRE RESISTANCE S-CSA+

Design under fire exposure is performed according to the design method given in EN 1992-4.

The data of these tables is based on: ETA-20/0446 and ETA-17/1009



- Concrete C20/25, $f_{ck,cube} = 25 \text{ N/mm}^2$
- Values cannot be used with hollow core slabs
- Installation has been done correctly.
- No influence of edge distances and spacings (see page 19)
- Respect of minimum base material thickness (see page 19)

Characteristic resistances, S-CSA+

| | | S-CSA+ 6 | | | | S-CSA+ 8 | | S-CSA+ 10 | | | S-CSA+ 14 | | |
|------------------------------------|------|-------------|-----------|----------|----------|-------------|------|--------------|------|------|--------------|------|------|
| | | PART 6 | PART 6 | OPT 1 | OPT 1 | OPT 1 | | OPT 1 | | | OPT 1 | | |
| Effective anchorage depth h_{ef} | [mm] | 27,6 | 31,9 | 29,8 | 42,5 | 39,2 | 51,9 | 42,5 | 55,3 | 68,0 | 49,3 | 66,3 | 91,8 |
| Nominal anchorage depth h_{nom} | [mm] | 35 | 40 | 40 | 55 | 50 | 65 | 55 | 70 | 85 | 65 | 85 | 115 |

| Fire Exposure R30 | Tension $N_{Rk,fi}$ | [kN] | 0,24 | 0,24 | 0,24 | 0,24 | 0,42 | 0,42 | 0,95 | 0,95 | 0,95 | 2,13 | 2,65 | 2,65 |
|----------------------|---------------------|------|------|------|------|------|------|------|------|------|------|------|------|------|
| | Shear $V_{Rk,fi}$ | [kN] | 0,24 | 0,24 | 0,24 | 0,24 | 0,42 | 0,42 | 0,95 | 0,95 | 0,95 | 2,65 | 2,65 | 2,65 |

| Fire Exposure R60 | Tension $N_{Rk,fi}$ | [kN] | 0,22 | 0,22 | 0,22 | 0,22 | 0,38 | 0,38 | 0,83 | 0,83 | 0,83 | 1,99 | 1,99 | 1,99 |
|----------------------|---------------------|------|------|------|------|------|------|------|------|------|------|------|------|------|
| | Shear $V_{Rk,fi}$ | [kN] | 0,22 | 0,22 | 0,22 | 0,22 | 0,38 | 0,38 | 0,83 | 0,83 | 0,83 | 1,99 | 1,99 | 1,99 |

| Fire Exposure R90 | Tension $N_{Rk,fi}$ | [kN] | 0,17 | 0,17 | 0,17 | 0,17 | 0,29 | 0,29 | 0,64 | 0,64 | 0,64 | 1,73 | 1,73 | 1,73 |
|----------------------|---------------------|------|------|------|------|------|------|------|------|------|------|------|------|------|
| | Shear $V_{Rk,fi}$ | [kN] | 0,17 | 0,17 | 0,17 | 0,17 | 0,29 | 0,29 | 0,64 | 0,64 | 0,64 | 1,73 | 1,73 | 1,73 |

| Fire Exposure R120 | Tension $N_{Rk,fi}$ | [kN] | 0,12 | 0,12 | 0,12 | 0,12 | 0,21 | 0,21 | 0,51 | 0,51 | 0,51 | 1,33 | 1,33 | 1,33 |
|-----------------------|---------------------|------|------|------|------|------|------|------|------|------|------|------|------|------|
| | Shear $V_{Rk,fi}$ | [kN] | 0,12 | 0,12 | 0,12 | 0,12 | 0,21 | 0,21 | 0,51 | 0,51 | 0,51 | 1,33 | 1,33 | 1,33 |

The recommended loads under fire exposure include a safety factor for resistance under fire exposure $\gamma_{M,fi} = 1,0$ and the partial safety factor for action $\gamma_{F,fi} = 1,0$. The partial safety factors for action shall be taken from national regulations.

FIRE RESISTANCE S-CSA A4

Design under fire exposure is performed according to the design method given in EN 1992-4.

The data of these tables is based on: ETA-22/0413



- Concrete C20/25, $f_{ck,cube} = 25 \text{ N/mm}^2$
- Values cannot be used with hollow core slabs
- Installation has been done correctly.
- No influence of edge distances and spacings (see page 20)
- Respect of minimum base material thickness (see page 20)

Characteristic resistances, S-CSA A4

| | | S-CSA A4 6 | | S-CSA A4 8 | | S-CSA A4 10 | |
|------------------------------------|---------------------------|---------------|------|---------------|------|----------------|------|
| | | OPT 1 | | OPT 1 | | OPT 1 | |
| Effective anchorage depth h_{ef} | [mm] | 34,0 | 42,5 | 35,8 | 48,5 | 39,1 | 64,6 |
| Nominal anchorage depth h_{nom} | [mm] | 45 | 55 | 50 | 65 | 55 | 85 |
| Fire Exposure R30 | Tension $N_{Rk, fi}$ [kN] | 0,24 | 0,24 | 0,75 | 0,85 | 1,70 | 1,70 |
| | Shear $V_{Rk, fi}$ [kN] | 0,24 | 0,24 | 0,85 | 0,85 | 1,70 | 1,70 |
| Fire Exposure R60 | Tension $N_{Rk, fi}$ [kN] | 0,22 | 0,22 | 0,68 | 0,68 | 1,36 | 1,36 |
| | Shear $V_{Rk, fi}$ [kN] | 0,22 | 0,22 | 0,68 | 0,68 | 1,36 | 1,36 |
| Fire Exposure R90 | Tension $N_{Rk, fi}$ [kN] | 0,17 | 0,17 | 0,51 | 0,51 | 1,09 | 1,09 |
| | Shear $V_{Rk, fi}$ [kN] | 0,17 | 0,17 | 0,51 | 0,51 | 1,09 | 1,09 |
| Fire Exposure R120 | Tension $N_{Rk, fi}$ [kN] | 0,12 | 0,12 | 0,42 | 0,42 | 0,95 | 0,95 |
| | Shear $V_{Rk, fi}$ [kN] | 0,12 | 0,12 | 0,42 | 0,42 | 0,95 | 0,95 |

The recommended loads under fire exposure include a safety factor for resistance under fire exposure $\gamma_{M,fi} = 1,0$ and the partial safety factor for action $\gamma_{F,fi} = 1,0$. The partial safety factors for action shall be taken from national regulations.

MATERIALS AND DIMENSIONS

Material quality and coating S-CSA+

Part

Coating ZP Zinc electroplated according to EN ISO 4042 $\geq 5 \mu\text{m}$

Coating ML Multi Layer coating $\geq 8 \mu\text{m}$

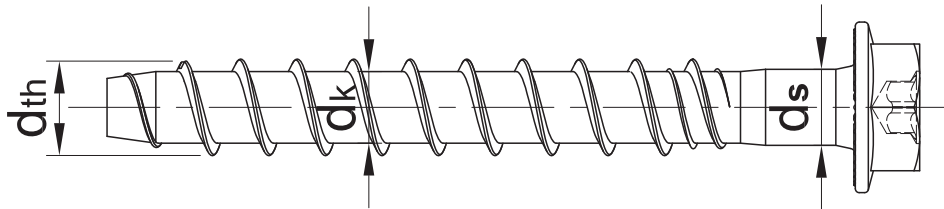

Mechanical properties S-CSA+

| Specification | | S-CSA 5 | | S-CSA+ 6 | | | S-CSA+ 8 | | S-CSA+ 10 | | | S-CSA+ 14 | | | |
|--------------------------------|--------------|----------------------|-----|----------|------|------|----------|------|-----------|------|------|-----------|-------|-------|-------|
| Effective anchorage depth | h_{ef} | [mm] | 19 | 27,5 | 27,6 | 31,9 | 42,5 | 39,2 | 51,9 | 42,5 | 55,3 | 68 | 49,3 | 66,3 | 91,8 |
| Nominal anchorage depth | h_{nom} | [mm] | 35 | 45 | 35 | 40 | 55 | 50 | 65 | 55 | 70 | 85 | 65 | 85 | 115 |
| Nominal Tension strength | F_{uk} | [N/mm ²] | 800 | | 800 | | | 800 | | 800 | | | 800 | | |
| Char. bending resistance | $M_{Rk,s}^0$ | [Nm] | 8,6 | | 16 | | | 37 | 37 | 69 | 69 | 69 | 207 | 207 | 207 |
| Design bending resistance | $M_{Rd,s}$ | [Nm] | 5,7 | | 12,8 | | | 29,6 | 29,6 | 52,2 | 55,2 | 55,2 | 165,6 | 165,6 | 165,6 |
| Recommended bending resistance | M_{rec} | [Nm] | 4,1 | | 9,1 | | | 21,1 | 21,1 | 39,4 | 39,4 | 35,4 | 118,3 | 118,3 | 118,3 |

| Specification | | S-CSA 5 | | S-CSA+ 6 | | S-CSA+ 8 | | S-CSA+ 10 | | S-CSA+ 14 | | |
|-------------------------------|-----------|--------------------|------|----------|-------------|----------|-------|-----------|-------|-----------|---------|--|
| Nominal diameter | d_{nom} | [mm] | 5,0 | | 6,0 | | 8,0 | | 10,0 | | 14,0 | |
| Thread outer diameter | d_{th} | [mm] | 6,12 | | 7,45 | | 10,50 | | 12,70 | | 16,55 | |
| Core diameter | d_k | [mm] | 4,50 | | 5,55 | | 7,30 | | 9,15 | | 13,00 | |
| Shaft diameter | d_s | [mm] | 4,9 | | 5,88 | | 7,80 | | 9,62 | | 13,40 | |
| Stressed section | A_s | [mm ²] | 15,9 | | 24,19 | | 42,43 | | 65,76 | | 132,73 | |
| Diameter of flange HEX | D | [mm] | 11,5 | | 16,5 | | 17,5 | | 20,5 | | 28/29,5 | |
| Diameter of flange I | D | [mm] | - | | 14,2 | | - | | - | | - | |
| Diameter of pan head P (P FL) | D | [mm] | - | | 14,5 (17,4) | | - | | - | | - | |
| Diameter of countersunk CS | D | [mm] | 9,8 | | 14 | | 18,2 | | - | | - | |

HEX

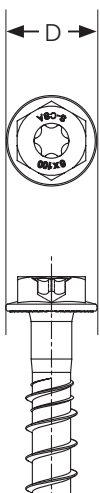

HEX WOF

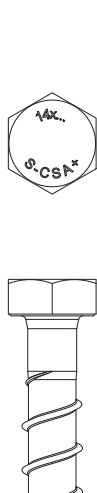

I

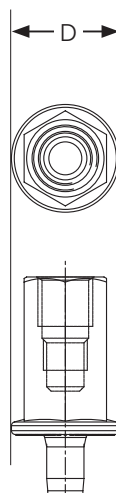

P

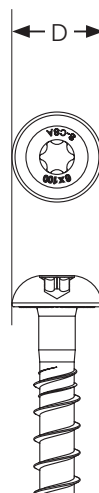

P FL

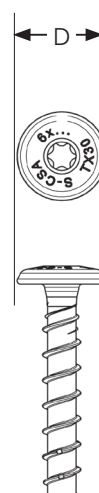

CS



E



MATERIALS AND DIMENSIONS

Material quality and coating S-CSA A4

Part

Material Cold forged stainless steel A4, hardened steel tip

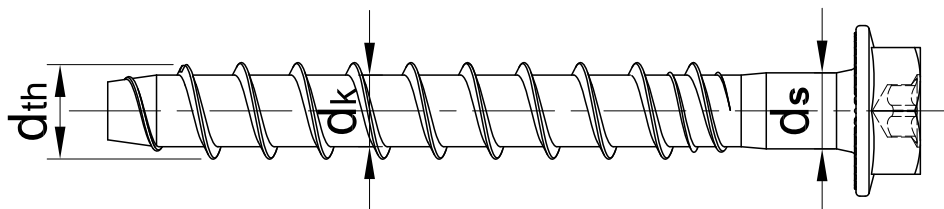

Mechanical properties

| Specification | | | S-CSA A4 6 | | S-CSA A4 8 | | S-CSA A4 10 | |
|--------------------------------|--------------|----------------------|------------|------|------------|------|-------------|------|
| Effective anchorage depth | h_{ef} | [mm] | 34 | 42,5 | 35,8 | 48,5 | 39,1 | 64,6 |
| Nominal anchorage depth | h_{nom} | [mm] | 45 | 55 | 50 | 65 | 55 | 85 |
| Nominal Tension strength | F_{uk} | [N/mm ²] | 800 | | 800 | | 705 | |
| Char. bending resistance | $M_{Rk,s}^0$ | [Nm] | 19,4 | | 45,6 | | 75,1 | |
| Design bending resistance | $M_{Rd,s}$ | [Nm] | 12,9 | | 30,4 | | 50,1 | |
| Recommended bending resistance | M_{rec} | [Nm] | 9,2 | | 21,7 | | 35,8 | |

| Specification | | | S-CSA A4 6 | S-CSA A4 8 | S-CSA A4 10 |
|----------------------------|-----------|--------------------|------------|------------|-------------|
| Nominal diameter | d_{nom} | [mm] | 6 | 8 | 10 |
| Thread outer diameter | d_{th} | [mm] | 7,45 | 9,9 | 11,9 |
| Core diameter | d_k | [mm] | 5,55 | 7,35 | 9,3 |
| Shaft diameter | d_s | [mm] | 5,9 | 7,85 | 9,67 |
| Stressed section | A_s | [mm ²] | 24,19 | 42,43 | 67,93 |
| Diameter of flange HEX | D | [mm] | 16,5 | 17,5 | 20,5 |
| Diameter of pan head P | D | [mm] | 14,5 | - | - |
| Diameter of countersunk CS | D | [mm] | 14 | - | - |
| Diameter of flange I | D | [mm] | 14,2 | - | - |

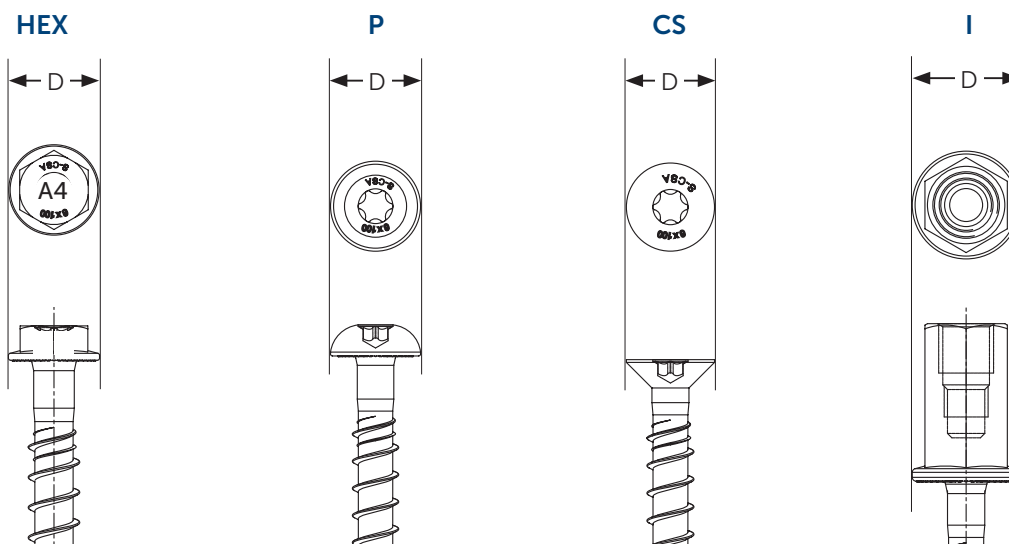

INSTALLATION INSTRUCTIONS

Installation equipment

| Specification | S-CSA 5 | S-CSA+ 6 | S-CSA+ 8 | S-CSA+ 10 | S-CSA+ 14 | S-CSA 6 A4 | S-CSA 8 A4 | S-CSA 10 A4 |
|------------------|--|-------------|-------------|--------------|--------------|---------------|---------------|----------------|
| Rotary hammer | 750...1200 r.p.m / 1.8 ...3.3 J | | | | | | | |
| Drill bit | SDS+ 2-CUT or 4-CUT sizes 5, 6, 8, 10, 14 mm | | | | | | | |
| Socket (SW) [mm] | 8 | 13 | 13 | 15 | 21 or 24 | 13 | 13 | 15 |
| T-drive / Torx | T25 | T30 | T45 | - | - | - | - | - |
| Additional tools | air pump/compressor, torque wrench, impact screw driver | | | | | | | |

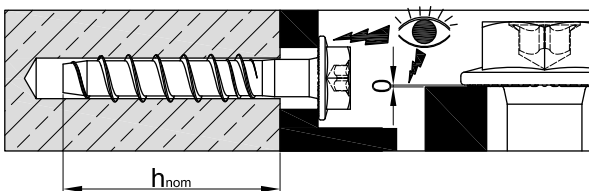
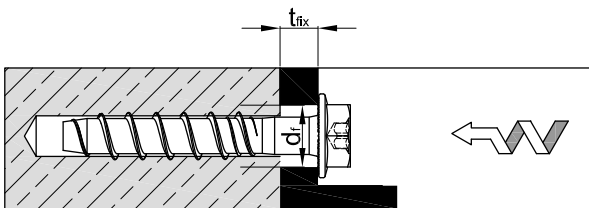
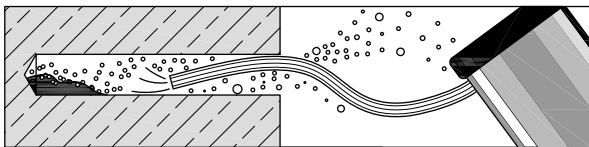
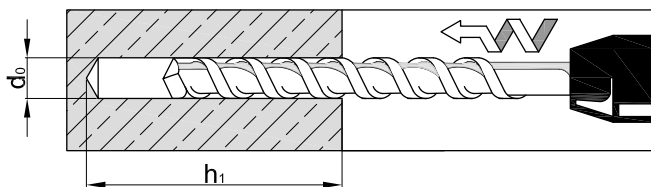

NOTES:

CONCRETE AND HOLLOW CORE SLAB

- Concrete strength is C20/25 to C50/60
Hollow core slabs C30/37 to C50/60
- No significant voids in concrete.
- Concrete is well compacted.
- Thickness of concrete is according PDS installation data.

INSTALLATION

Edge distances and spacing are according PDS installation data.

- Use proper air pump or compressor.
- Drill hole is deep enough (mentioned h_1 in PDS installation data).
- All dust should be cleaned from the hole to avoid screw jamming during installation.
- Pay special attention to cleaning, especially when installing downwards.
- In case of aborted hole, drilling of new hole at a minimum distance of twice the depth of the aborted hole, or smaller distance provided the aborted drill hole is filled with high strength non-shrinkage mortar. No shear or oblique tension loads are allowed in the direction of a not filled aborted hole.

OTHER BASE MATERIALS

- Concrete screw can be used also in other base materials such as solid clay brick and solid sand-lime brick.

INSTALLATION S-CSA+

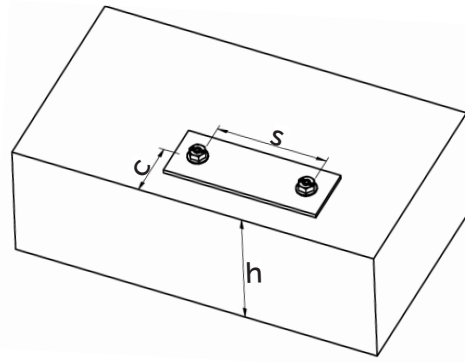
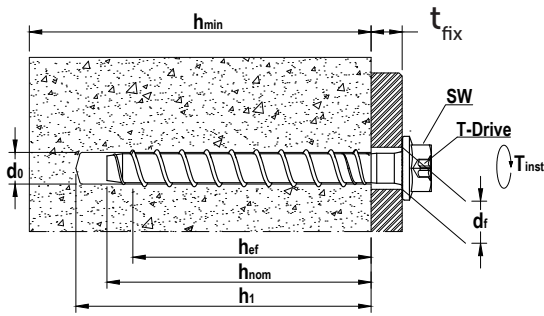

Installation data S-CSA+

| Specification | | | S-CSA 5 | | S-CSA+ 6 | | | | S-CSA+ 8 | | S-CSA+ 10 | | | S-CSA+ 14 | | |
|--|--------------------|------|---------|------|----------|--------|-------|-------|-----------|-------|-----------|-------|-------|-----------|-------|-------|
| Assessment | | | - | - | PART 6 | PART 6 | OPT 1 | OPT 1 | OPT 1 | OPT 1 | OPT 1 | OPT 1 | OPT 1 | OPT 1 | OPT 1 | OPT 1 |
| Drill hole diameter | d_0 | [mm] | 5 | | 6 | | | | 8 | | 10 | | | 14 | | |
| Cutting diameter at the upper tolerance limit (max. diam. bit) | $d_{cut,max \leq}$ | [mm] | 5,40 | | 6,40 | | | | 8,45 | | 10,45 | | | 14,50 | | |
| Depth of drilled hole to deepest point | $h_{1 \geq}$ | [mm] | 45 | 55 | 45 | 50 | 50 | 65 | 60 | 75 | 65 | 80 | 95 | 75 | 95 | 125 |
| Effective anchorage depth | h_{ef} | [mm] | 19,0 | 27,5 | 27,6 | 31,9 | 29,8 | 42,5 | 39,2 | 51,9 | 42,5 | 55,3 | 68 | 49,3 | 66,3 | 91,8 |
| Nominal anchorage depth | h_{nom} | [mm] | 35 | 45 | 35 | 40 | 40 | 55 | 50 | 65 | 55 | 70 | 85 | 65 | 85 | 115 |
| Diameter of clearance hole in the fixture | d_f | [mm] | 6,3-7,0 | | 7,7-9,0 | | | | 10,8-12,0 | | 13,0-14,0 | | | 17,0-18,0 | | |
| Max. torque, manual | T_{inst} | [Nm] | 12 | | 14 | | | | 45 | | 85 | | | 100 | | |
| Max. torque, impact screw driver | T_{SD} | [Nm] | - | | 90 | | | | 290 | | 650 | | | 650 | | |
| Width across flats | SW | [mm] | 8 | | 13 | | | | 13 | | 15 | | | 21 / 24 | | |
| T-drive (in types HEX, CS and P) | T-drive | | CS | T25 | T30 | | | | T45 | | - | | | - | | |

Minimum thickness of concrete member, spacing and edge distance S-CSA+

| Cracked and uncracked concrete | | | S-CSA 5 | | S-CSA+ 6 | | | | S-CSA+ 8 | | S-CSA+ 10 | | | S-CSA+ 14 | | |
|---|-------------|------|---------|------|----------|------|-------------|------|----------|-------|-----------|-------|-------|-----------|------|-------|
| Assessment | | | - | - | PART 6 | | OPT 1 | | OPT 1 | | OPT 1 | | | OPT 1 | | |
| Effective anchorage depth | h_{ef} | [mm] | 19,0 | 27,5 | 27,6 | 31,9 | 29,8 | 42,5 | 39,2 | 51,9 | 42,5 | 55,3 | 68 | 49,3 | 66,3 | 91,8 |
| Nominal anchorage depth | h_{nom} | [mm] | 35 | 45 | 35 | 40 | 40 | 55 | 50 | 65 | 55 | 70 | 85 | 65 | 85 | 115 |
| Minimum thickness of base material | h_{min} | [mm] | 80 | 80 | 80 | 80 | 80 | 92,7 | 100 | 112,7 | 100 | 112,8 | 125,5 | 120 | 137 | 162,5 |
| Minimum spacing | s_{min} | [mm] | 35 | 35 | 35 | 35 | 35 | 35 | 35 | 35 | 40 | 40 | 40 | 60 | 60 | 60 |
| Minimum edge distance | c_{min} | [mm] | 35 | 35 | 30 | 35 | 35 | 35 | 35 | 35 | 40 | 40 | 40 | 60 | 60 | 60 |
| Critical spacing for splitting failure and concrete cone failure (in case characteristic loading affects) | $s_{cr,sp}$ | [mm] | 53 | 83 | 110 | 96 | ETA-20/0446 | | | | | | | | | |
| | $s_{cr,N}$ | [mm] | 53 | 83 | 83 | 96 | 89 | 128 | 118 | 156 | 128 | 165 | 204 | 148 | 198 | 275 |
| Critical edge distance for splitting failure and concrete cone failure (in case characteristic loading affects) | $c_{cr,sp}$ | [mm] | 27 | 41 | 55 | 48 | ETA-20/0446 | | | | | | | | | |
| | $c_{cr,N}$ | [mm] | 27 | 41 | 41 | 48 | 44 | 64 | 59 | 78 | 64 | 82 | 102 | 74 | 99 | 138 |

INSTALLATION S-CSA A4

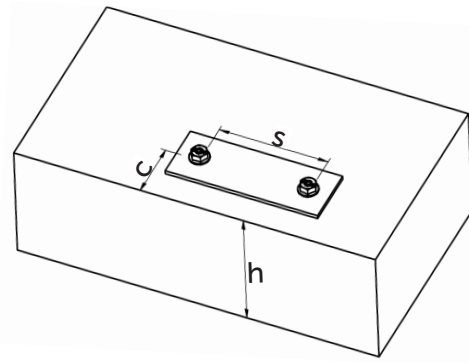
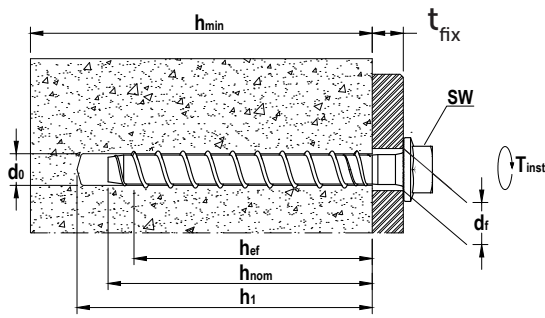

Installation data S-CSA A4

| Specification | | | S-CSA A4 6 | | | S-CSA A4 8 | | S-CSA A4 10 | |
|--|--------------------|------|-------------------|------------------|------|------------------|------|------------------|------|
| Assessment | | | PART 6 | OPT 1 | | OPT 1 | | OPT 1 | |
| Drill hole diameter | d_0 | [mm] | 6 | 6 | | 8 | | 10 | |
| Cutting diameter at the upper tolerance limit (max. diam. bit) | $d_{cut,max \leq}$ | [mm] | 6,4 | 6,4 | | 8,45 | | 10,45 | |
| Depth of drilled hole to deepest point | $h_{1 \geq}$ | [mm] | 50 | 55 | 65 | 60 | 75 | 65 | 95 |
| Effective anchorage depth | h_{ef} | [mm] | 31,9 | 34 | 42,5 | 35,8 | 48,5 | 39,1 | 64,6 |
| Nominal anchorage depth | h_{nom} | [mm] | 40 | 45 | 55 | 50 | 65 | 55 | 85 |
| Diameter of clearance hole in the fixture | d_f | [mm] | 7,7-9,0 | ≤ 9 | | ≤ 12 | | ≤ 14 | |
| Max. torque, manual | $T_{inst} \leq$ | [Nm] | 14 | 14 | | 40 | | 75 | |
| Max. torque, impact screw driver | T_{SD} | [Nm] | 90 | 90 | | 290 | | 360 | |
| Width across flats | SW | [mm] | 13 | 13 | | 13 | | 15 | |
| T-drive (in types CS and P) | T-drive | | T30 | T30 | | - | | - | |

Minimum thickness of concrete member, spacing and edge distance S-CSA A4

| Cracked and uncracked concrete | | | S-CSA A4 6 | | | S-CSA A4 8 | | S-CSA A4 10 | |
|--|-------------|------|-------------------|------------------|-------|------------------|-------|------------------|-------|
| Assessment | | | PART 6 | OPT 1 | | OPT 1 | | OPT 1 | |
| Effective anchorage depth | h_{ef} | [mm] | 31,9 | 34 | 42,5 | 35,8 | 48,5 | 39,1 | 64,6 |
| Nominal anchorage depth | h_{nom} | [mm] | 40 | 45 | 55 | 50 | 65 | 55 | 85 |
| Minimum thickness of base material | h_{min} | [mm] | 80 | 80 | 100 | 100 | 100 | 100 | 100 |
| Minimum spacing | s_{min} | [mm] | 35 | 35 | 35 | 35 | 35 | 40 | 40 |
| Minimum edge distance | c_{min} | [mm] | 35 | 35 | 35 | 35 | 35 | 40 | 40 |
| Critical spacing for splitting failure and concrete cone failure (in case characteristic loading affects) | $s_{cr,sp}$ | [mm] | 120 | 136,0 | 127,5 | 121,7 | 165,0 | 195,5 | 184,5 |
| | $s_{cr,N}$ | [mm] | 96 | 102,0 | 127,5 | 107,4 | 145,5 | 117,3 | 193,8 |
| Critical edge distance for splitting failure and concrete cone failure (in case characteristic loading affects) | $c_{cr,sp}$ | [mm] | 60 | 68,0 | 63,8 | 60,9 | 82,5 | 97,8 | 92,3 |
| | $c_{cr,N}$ | [mm] | 48 | 51,0 | 63,8 | 53,7 | 72,8 | 58,7 | 96,9 |

S-CSA+ 10 & 14 REUSABILITY

DIBt Z-21.8-2136 approves the reuse of the S-CSA+ concrete screw, 10 and 14 mm diameter in combination with the CG+ checking gauge. The checking gauge is a tool for measuring the reusability of the S-CSA+ 10 & 14 concrete screw for temporary applications. The checking must be performed before each reuse.

Field of application

S-CSA+ 10 and 14 shall only be applied for temporary fastening of construction site equipment, such as shoring props, fall protection devices or scaffolds. After it has been unscrewed, the fastener may be reused in other drill holes. However, a drilled hole shall not be reused after the fastener has been removed. Reusability of the fastener shall be checked prior to every use, both visually as well as with a checking gauge in accordance with installation parameters. Installed fasteners shall be checked for visible damage (for example due to corrosion) on an ongoing basis and replaced if required. The fastener may be used in cracked and uncracked concrete. The fastener is intended for temporary use in internal and external conditions.

Installation

S-CSA+ 10 and 14 is only intended for temporary application in a single drilled hole. After it has been removed, it may be reused in other drilled holes. However, it may not be screwed into the same drilled hole for a second time. Prior to every reuse, the wear of the thread shall be verified with an appropriate checking gauge (CG+). The fastener shall only be reused under the condition that it will penetrate the sleeve only so far that it does not protrude at the rear of the sleeve (see page 22). Screws which are visibly damaged, e.g. due to corrosion, shall not be reused. The fastener may be screwed in using an impact screw driver. To prevent the screw from spinning, the screw driver with a power output in the upper range shall be equipped with an automatic cut-off device, e.g. via a depth stop.

The fastener is installed correctly if

- the base plate (fixture) is screwed flush against the concrete without an intermediate layer,
- the fastener head is fully in contact with the base plate,
- the fastener cannot easily be turned further,
- the anchorage depth h_{nom} is adhered to.

| Anchor size | | | S-CSA+ 10 | | | S-CSA+ 14 | | |
|--|---------------|------|-----------|------|-------|-----------|------|-------|
| Nominal anchorage depth | h_{nom} | [mm] | 55 | 70 | 85 | 65 | 85 | 115 |
| Design resistance for concrete with a compressive strength F_{ck} cylinder ≥ 8 N/mm ² | $F_{Rd}^{1)}$ | [kN] | 2,00 | 4,67 | 6,33 | 3,00 | 5,67 | 12,00 |
| Design resistance for concrete with a compressive strength F_{ck} cylinder ≥ 12 N/mm ² | $F_{Rd}^{1)}$ | [kN] | 3,00 | 5,67 | 8,67 | 4,00 | 6,67 | 13,33 |
| Design resistance for concrete with a compressive strength F_{ck} cylinder ≥ 16 N/mm ² | $F_{Rd}^{1)}$ | [kN] | 4,33 | 6,33 | 11,33 | 5,00 | 7,33 | 16,00 |
| Design resistance for concrete with a compressive strength F_{ck} cylinder ≥ 20 N/mm ² | $F_{Rd}^{1)}$ | [kN] | 5,33 | 6,67 | 13,33 | 6,00 | 8,00 | 18,67 |

¹⁾ Design resistance incl. partial safety factor.

S-CSA+ 10 & 14 REUSABILITY

Checking gauge CG+



Gauge CG+ 10

Gauge inner diameter d_c 12,1 [mm]

Length l_c 30 [mm]

Gauge CG+ 14

Gauge inner diameter d_c 15,8 [mm]

Length l_c 40 [mm]

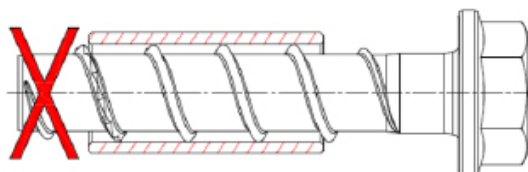
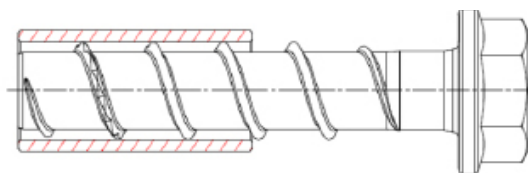
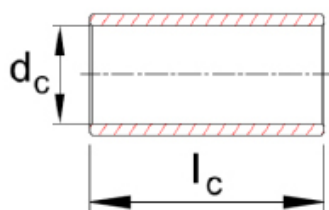

CONCRETE SCREWS

DELIVERY PROGRAM

• Option 1

• Part 6

| S-CSA HEX | Size | t _{fix} | ETA |
|-----------|------|------------------|-----|
| 5 | 5x40 | 5 | - |
| | 5x50 | 5 | - |

Zinc plated

| S-CSA+ HEX | Size | t _{fix} | ETA |
|----------------------|---------------------------|------------------|-----|
| 6 | 6x35 | 1 | ● |
| | 6x45 | 5/10 | ● |
| | 6x50 | 10/15 | ● |
| | 6x60 | 5/20 | ● ● |
| | 6x70 | 15/30 | ● ● |
| | 6x80 | 25/40 | ● ● |
| | 6x100 | 45/60 | ● ● |
| | 6x120 | 65/80 | ● ● |
| 8 | 8x55 | 5 | ● |
| | 8x70 | 5/20 | ● |
| | 8x80 | 15/30 | ● |
| | 8x90 | 25/40 | ● |
| | 8x100 | 35/50 | ● |
| | 8x120 | 55/70 | ● |
| | 8x140 | 75/90 | ● |
| | 8x200 | 135/150 | ● |
| 10 | 10x60 | 5 | ● |
| | 10x70 | 15 | ● |
| | 10x80 | 10/25 | ● |
| | 10x90 | 5/35 | ● |
| | 10x100 | 15/45 | ● |
| | 10x120 | 35/65 | ● |
| | 10x140 | 55/85 | ● |
| | 10x160 | 75/105 | ● |
| | 10x200 | 115/145 | ● |
| | 10x240 | 155/185 | ● |
| 14 | 14x75 <u>SW21</u> | 10 | ● |
| | 14x100 <u>SW21</u> | 15/35 | ● |
| | 14x130 <u>SW21</u> | 15/65 | ● |
| | 14x150 <u>SW21</u> | 35/85 | ● |
| | 14x80 <u>SW24</u> (WOF) * | 15 | ● |
| | 14x110 <u>SW24</u> * | 25/45 | ● |
| 14x130 <u>SW24</u> * | 15/65 | ● | |

Zinc plated or Multi Layer coating, * = Only ZP

S-CSA+ 10 & 14 checking gauge for re-usability



| S-CSA CS | Size | t _{fix} | ETA |
|----------|-------|------------------|-----|
| 5 | 5x50 | 5 | - |
| | 5x75 | 30 | - |
| | 5x100 | 55 | - |

Zinc plated

| S-CSA+ CS | Size | t _{fix} | ETA |
|-----------|--------|------------------|-----|
| 6 | 6x45 | 5/10 | ● |
| | 6x50 | 10/15 | ● |
| | 6x60 | 5/20 | ● ● |
| | 6x80 | 25/40 | ● ● |
| | 6x100 | 45/60 | ● ● |
| | 6x120 | 65/80 | ● ● |
| | 8x60 | 10 | ● |
| | 8x80 | 15/30 | ● |
| | 8x100 | 35/50 | ● |
| | 10x70 | 15 | ● |
| | 10x90 | 5/35 | ● |
| | 10x100 | 15/45 | ● |
| | 10x120 | 35/65 | ● |

Zinc plated, Multi Layer coating

| S-CSA+ P (L) | Size | t _{fix} | ETA |
|--------------|------|------------------|-----|
| 6 | 6x35 | 1 | ● |
| | 6x45 | 5/10 | ● |
| | 6x60 | 5/20 | ● ● |

Zinc plated, L = Low pan head

| S-CSA+ P (FL) | Size | t _{fix} | ETA |
|---------------|------|------------------|-----|
| 6 | 6x40 | 5 | ● |
| | 6x60 | 5/20 | ● ● |

Zinc plated, Multi Layer, FL = Flat panhead

| S-CSA+ I | Size | ETA |
|--|------------------|-----|
|  6 | 6x35 M8/M10x30 * | ● |
| | 6x45 M8/M10x30 | ● |
| | 6x60 M8/M10x30 | ● ● |

Zinc plated, * = Also ML

| S-CSA+ E | Size | ETA |
|--|------------|-----|
|  6 | 6x35 M8x16 | ● |
| | 6x60 M8x16 | ● ● |

Zinc plated

| S-CSA HEX A4 | Size | t _{fix} | ETA |
|--|--------|------------------|-----|
|  6 | 6x50 | 5 | ● ● |
| | 6x60 | 5/15 | ● ● |
| | 6x70 | 15/25 | ● ● |
| | 6x80 | 25/35 | ● ● |
| 8 | 8x55 | 5 | ● |
| | 8x70 | 5/20 | ● |
| | 8x80 | 15/30 | ● |
| | 8x100 | 35/50 | ● |
| 10 | 10x90 | 5/35 | ● |
| | 10x100 | 15/45 | ● |
| | 10x120 | 35/65 | ● |

Stainless Steel A4, hardened tip, coated

| S-CSA P A4 | Size | t _{fix} | ETA |
|--|-------|------------------|-----|
|  | 6x50 | 5 | ● ● |
| | 6x60 | 5/15 | ● ● |
| | 6x80 | 25/35 | ● ● |
| | 6x100 | 45/55 | ● ● |

Stainless Steel A4, hardened tip, coated

| S-CSA CS A4 | Size | t _{fix} | ETA |
|---|-------|------------------|-----|
|  | 6x50 | 5 | ● ● |
| | 6x60 | 5/15 | ● ● |
| | 6x70 | 15/25 | ● ● |
| | 6x100 | 45/55 | ● ● |

Stainless Steel A4, hardened tip, coated

| S-CSA I A4 | Size | ETA |
|---|----------------|-----|
|  | 6x50 M8/M10x30 | ● ● |

Stainless Steel A4, hardened tip, coated