

# TLM

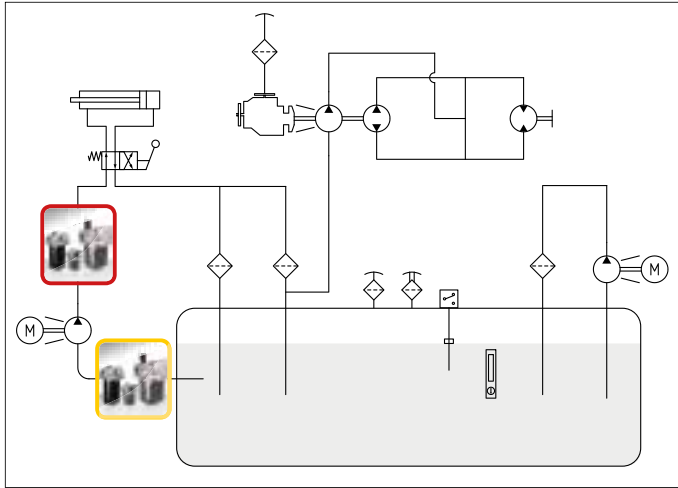

SUCTION OR LOW PRESSURE FILTER, 90° CONNECTION PORTS





## TLM

### 2 MPa (20 bar)

Port sizes: 3/8" ÷ 1" 1/2  
Flow rates: 4 ÷ 600 l/min

#### TECHNICAL DATA

Max. working pressure: 2 MPa (20 bar)  
Max. test pressure: 4 MPa (40 bar)  
Bursting pressure: 6 MPa (60 bar)  
Fatigue test: 0 ÷ 1 MPa (10 bar) / 300.000 cycles

Filter element collapse pressure:  
standard:  $\Delta p$  300 kPa (3 bar) all types

Working temperature: -25 ÷ +110°C

#### MATERIALS

Head: aluminium  
Bowl: painted steel  
Seals: standard NBR  
on request FKM

#### COMPATIBILITY (ISO 2943)

Full with fluids: HH-HL-HM-HV-HTG  
(according to ISO 6743/4).  
For fluids different than the above mentioned,  
please contact our Sales Department.

All tests performed according  
to the following standards:

ISO 2941: Element collapse resistance test  
ISO 2942: Production integrity test  
ISO 2943: Fluids compatibility  
ISO 3723: End load test method  
ISO 3724: Flow fatigue resistance method  
ISO 3968: Pressure drop versus flow rate  
ISO 16889: Multipass test.

For further information contact our Technical Dept.

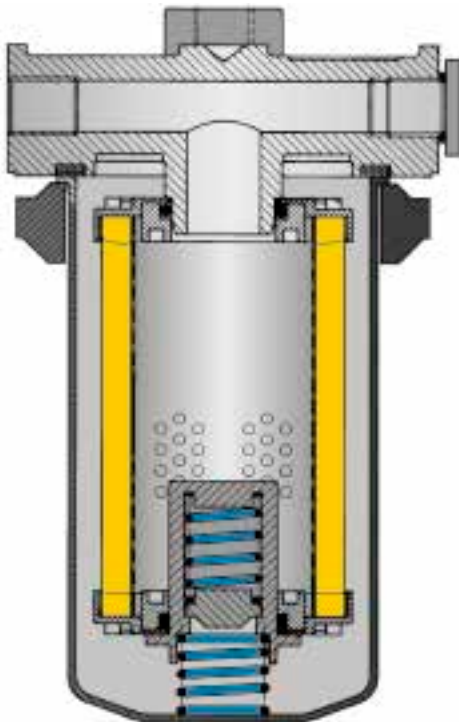

## HOW TO ORDER THE COMPLETE FILTER

## HOW TO ORDER THE FILTER ELEMENT

<b>TLM</b>	Type	019	055	115	150	Type	<b>CRE</b>
		015	048	058	100		

	Filter media				Filter media			
	FD = 12 $\mu$ m <sub>(c)</sub>	Inorganic fiber $\beta$ >1000	FD	FD	FD	FD	FD = 12 $\mu$ m <sub>(c)</sub>	Inorganic fiber $\beta$ >1000
	FV = 21 $\mu$ m <sub>(c)</sub>		FV	FV	FV	FV	FV = 21 $\mu$ m <sub>(c)</sub>	
	CD = 10 $\mu$	Paper	CD	CD	CD	CD	CD = 10 $\mu$	Paper
	CV = 25 $\mu$		CV	CV	CV	CV	CV = 25 $\mu$	
	MS = 60 $\mu$	Steel wire mesh	MS	MS	MS	MS	MS = 60 $\mu$	Steel wire mesh
MN = 90 $\mu$	MN		MN	MN	MN	MN = 90 $\mu$		

	Seals				Seals			
	1 = NBR Nitrile	1	1	1	1	1 = NBR Nitrile		
	2 = FKM Fluoroelastomer	2	2	2	2	2 = FKM Fluoroelastomer		

<b>B</b>	Bypass type			
	B = 170 kPa (1,7 bar)	B	B	B

	Ports				
	B = BSP	B	B	B	B
	N = NPT	N	N	N	N

	Port size				
	2 = 3/8"	2	-	-	-
	3 = 1/2"	3	-	-	-
	4 = 3/4"	-	4	-	-
	5 = 1"	-	5	-	-
	6 = 1" 1/4	-	-	6	-
	7 = 1" 1/2	-	-	-	7

	Indicators				Indicator 70 on request only  Return line  Suction line	
	03 = Port, plugged	03	03	03		03
	5B = Visual differential 130 kPa (1,3 bar)	5B	5B	5B		5B
	6B = Electrical differential 130 kPa (1,3 bar)	6B	6B	6B		6B
	7B = 6B with LED	7B	7B	7B		7B
	T0 = Electrical 130 kPa (1,3 bar) with thermostat 30°C	T0	T0	T0		T0
	0R = 1/8" Predisposition	0R	0R	0R		0R
	31 = Pressure gauge	31	31	31		31
	P1 = Pressure switch	P1	P1	P1		P1
	08 = 1/8" Port, plugged	08	08	08		08
	10 = Vacuum gauge	10	10	10		10
	91 = Vacuum switch	91	91	91		91

When the filter is ordered with FKM seals, the first digit of the indicator code is a letter (please see page 188-189).

<b>XX</b>	Accessories			
	XX = Not available	XX	XX	XX

**DIMENSIONAL LAYOUT**

(mm)

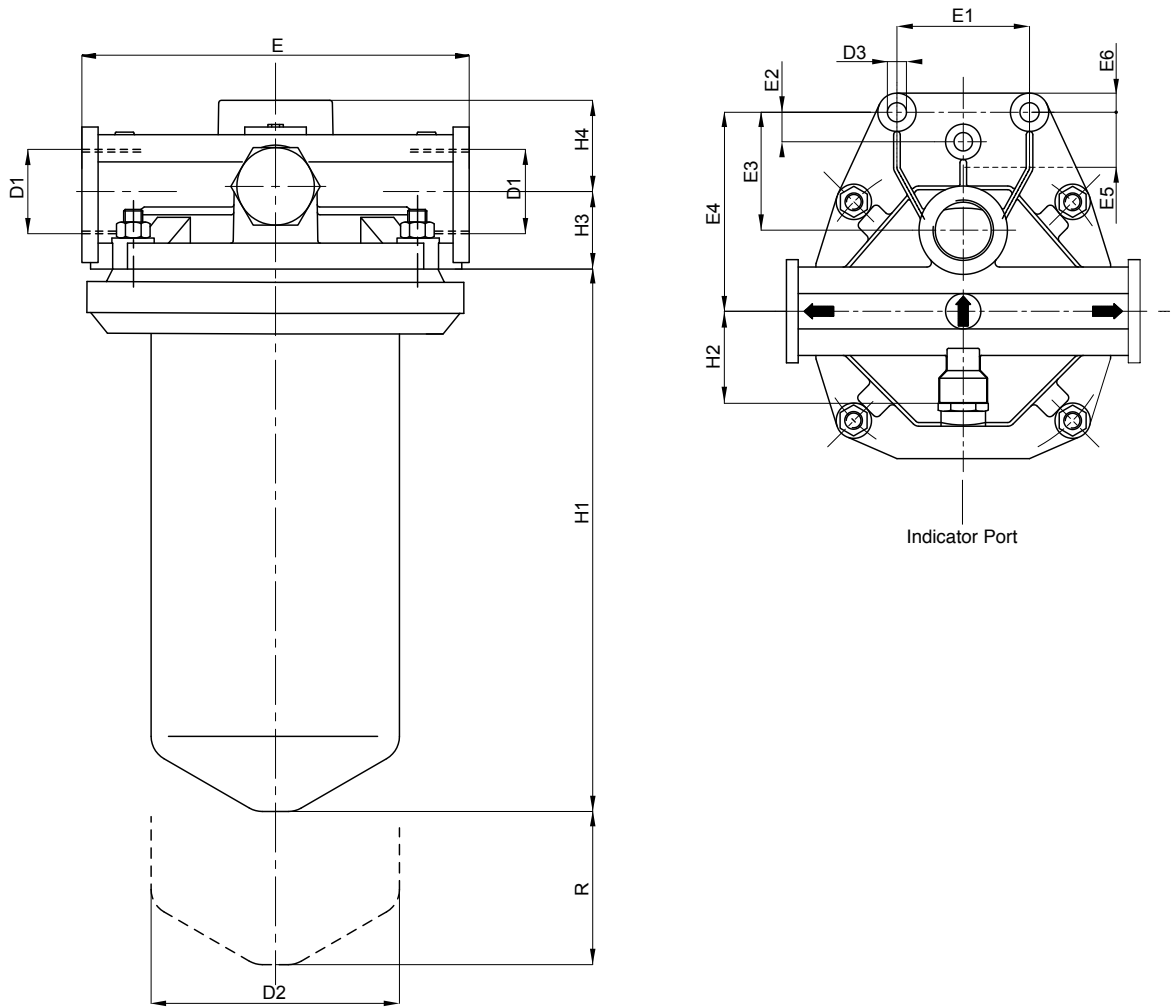

Type	D1	D2	D3	E	E1	E2	E3	E4	E5	E6	H1	H2	H3	H4	R	Weight Kg
TLM 019	3/8" - 1/2"	81	10,5	114	50	-	42	70	15	10	114	44	19	27	20	1,3
TLM 055	3/4" - 1"	114	13	150	50	-	50	85	12	13	204	58	30	35	20	3,2
TLM 115	1" 1/4	156	13	240	90	20	80	135	56	13	200	62	38	45	25	6,1
TLM 150	1" 1/2	156	13	240	90	20	80	135	56	13	250	62	38	45	25	6,8

# CLOGGING INDICATORS

## RETURN LINE

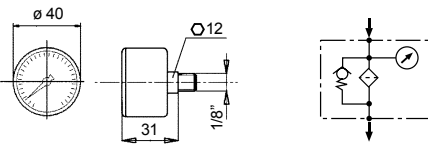
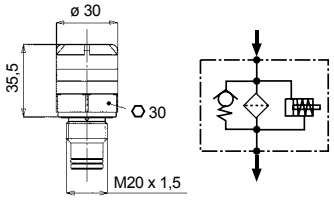
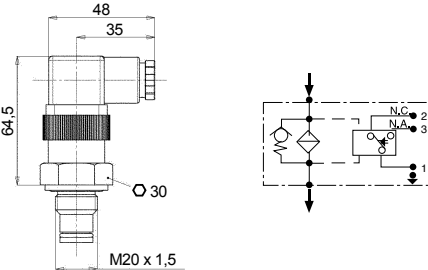
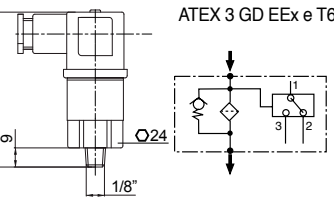
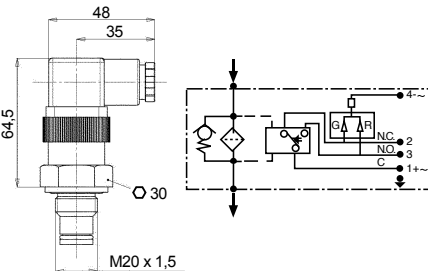
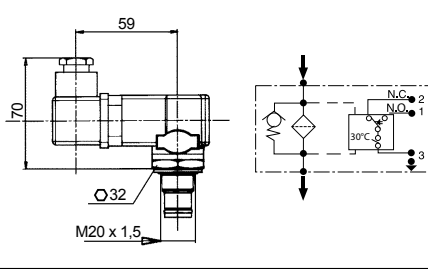
NBR	FKM	Pressure Gauge		NBR	FKM	Diff. VISUAL indicator	
31	-	Scale 0÷1,2 MPa (12 bar)		5B	AB	Setting 130 kPa (1,3 bar)	Recommended tightening torque 90 Nm 
NBR	FKM	Diff. ELECT. indicators	Recommended tightening torque 90 Nm 	NBR	FKM	Pressure switch	Recommended tightening torque 90 Nm 
6B	CB	Setting 130 kPa (1,3 bar)		P1	-	Setting 150 kPa (1,5 bar)	
NBR	FKM	Diff. ELECT. ind. + LED (24V)	Recommended tightening torque 90 Nm 	For indicator P1 : SPDT, C.C. 30V: > max resistive or inductive load 3A - 1A respectively C.A. 125 or 250V: > max resistive or inductive load 3A - 0,5A respectively Protection IP65 - Connector DIN 43650			
7B	EB	Setting 130 kPa (1,3 bar)					
NBR	FKM	Diff. ELECT. ind. + Thermostat 30°C	Recommended tightening torque 90 Nm 				
T0	DB	Setting 130 kPa (1,3 bar)					
For indicator 6B - 7B - T0 : SPDT differential switch, C.C. 14 - 30 V: > max resistive or inductive load 4 - 3A respectively C.A. 125-250 V: > max resistive or inductive load 1 A Protection IP65 - Connector DIN 43650							

## SUCTION LINE

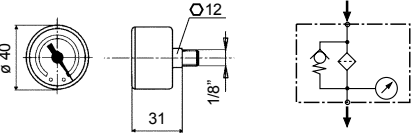
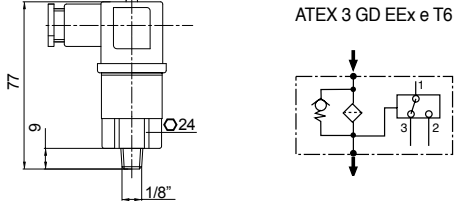
NBR	FKM	Vacuum gauge	
10	-	Scale 0 ÷ 100 kPa (100 bar)	
NBR	FKM	Pressure switch	
91	-	Setting 20 kPa (0,2 bar)	
SPDT, C.C. 30V: > max resistive or inductive load 3A - 1A respectively C.A. 125 or 250V: > max resistive or inductive load 3A - 0,5A respectively Protection IP65 - Connector DIN 43650			

## FLOW RATES

(l/min)

Type	Filter Media	Δ p ...		
		5 kPa (0,05 bar)	20 kPa (0,2 bar)	40 kPa (0,4 bar)
TLM 019 ...BB2	FD	4	16	26
	FV	6	18	35
	CD	6	21	34
	CV	7	23	40
	MS	8	25	44
	MN	8	27	49
TLM 019 ...BB3	FD	7	23	46
	FV	9	27	55
	CD	9	28	53
	CV	11	34	62
	MS	13	38	64
	MN	15	42	68
TLM 055 ...BB4	FD	13	48	89
	FV	16	52	95
	CD	16	61	106
	CV	19	68	117
	MS	21	76	132
	MN	23	87	140
TLM 055 ...BB5	FD	21	76	143
	FV	28	93	162
	CD	25	98	167
	CV	34	121	182
	MS	36	129	197
	MN	49	148	208
TLM 115	FD	30	132	250
	FV	38	197	298
	CD	38	170	291
	CV	49	216	334
	MS	57	223	379
	MN	68	265	409
TLM 150	FD	49	230	365
	FV	77	303	410
	CD	68	276	409
	CV	106	352	462
	MS	114	371	511
	MN	182	428	568

The reference fluid has a kinematic viscosity of 30 cSt and a density of 0,86 Kg/dm<sup>3</sup>.  
For different oil viscosity please contact our Sales Department for further information.

## FILTER AREA

(cm<sup>2</sup>)

Type	Filter Media					
	CD	CV	MS	MN	FD	FV
CRE 015	990	990	460	460	620	620
CRE 048	3390	3390	1600	1600	3010	3010
CRE 058	4360	4360	2550	2550	4140	4140
CRE 100	6520	6520	2955	2955	6190	6190