

Impro
Fluidtek

Technical Information

Orbital Motors Type RC/RE



TABLE OF CONTENTS

TECHNICAL INFORMATION

Operating Recommendations 4-5
 Motor Connections 5
 Product Testing (Understanding the Performance Charts)..... 6
 Allowable Bearing & Shaft Loads 7
 Vehicle Drive Calculations 8-9
 Induced Side Loading..... 10
 Hydraulic Equations..... 10
 Shaft Nut Dimensions & Torque Specifications 11

OPTIONAL MOTOR FEATURES

Speed Sensor Options 12-13
 Freeturning Rotor Option 13
 Internal Drain 14
 Hydraulic Declutch..... 14
 Valve Cavity Option 15
 Slinger Seal Option..... 15

MEDIUM DUTY HYDRAULIC MOTORS

RE Product Line Introduction..... 16
 RE Displacement Performance Charts..... 17-22
 505 & 506 Series Housings 23-24
 505 & 506 Series Technical Information 25
 505 & 506 Series Shafts..... 26
 505 & 506 Series Ordering Information 27
 530 & 531 Series Housings 28
 530 & 531 Series Technical Information 29
 530 & 531 Series Shafts..... 30
 530 & 531 Series Ordering Information 31
 535 & 536 Series Housings 32
 535 & 536 Series Technical Information 32
 535 & 536 Series Shafts..... 33
 535 & 536 Series Ordering Information 33

OPERATING RECOMMENDATIONS

OIL TYPE

Hydraulic oils with anti-wear, anti-foam and demulsifiers are recommended for systems incorporating Impro Fluidtek motors. Straight oils can be used but may require VI (viscosity index) improvers depending on the operating temperature range of the system. Other water based and environmentally friendly oils may be used, but service life of the motor and other components in the system may be significantly shortened. Before using any type of fluid, consult the fluid requirements for all components in the system for compatibility. Testing under actual operating conditions is the only way to determine if acceptable service life will be achieved.

FLUID VISCOSITY & FILTRATION

Fluids with a viscosity between 20 - 43 cSt [100 - 200 S.U.S.] at operating temperature is recommended. Fluid temperature should also be maintained below 85°C [180° F]. It is also suggested that the type of pump and its operating specifications be taken into account when choosing a fluid for the system. Fluids with high viscosity can cause cavitation at the inlet side of the pump. Systems that operate over a wide range of temperatures may require viscosity improvers to provide acceptable fluid performance.

Impro Fluidtek recommends maintaining an oil cleanliness level of ISO 17-14 or better.

INSTALLATION & START-UP

When installing an Impro Fluidtek motor it is important that the mounting flange of the motor makes full contact with the mounting surface of the application. Mounting hardware of the appropriate grade and size must be used. Hubs, pulleys, sprockets and couplings must be properly aligned to avoid inducing excessive thrust or radial loads. Although the output device must fit the shaft snug, a hammer should never be used to install any type of output device onto the shaft. The port plugs should only be removed from the motor when the system connections are ready to be made. To avoid contamination, remove all matter from around the ports of the motor and the threads of the fittings. Once all system connections are made, it is recommended that the motor be run-in for 15-30 minutes at no load and half speed to remove air from the hydraulic system.

MOTOR PROTECTION

Over-pressurization of a motor is one of the primary causes of motor failure. To prevent these situations, it is necessary to provide adequate relief protection for a motor based on the pressure ratings for that particular model. For systems that may experience overrunning conditions, special precautions must be taken. In an overrunning condition, the motor functions as a pump and attempts to convert kinetic energy into hydraulic energy. Unless the system is properly

configured for this condition, damage to the motor or system can occur. To protect against this condition a counterbalance valve or relief cartridge must be incorporated into the circuit to reduce the risk of over-pressurization. If a relief cartridge is used, it must be installed upline of the motor, if not in the motor, to relieve the pressure created by the over-running motor. To provide proper motor protection for an over-running load application, the pressure setting of the pressure relief valve must not exceed the intermittent rating of the motor.

HYDRAULIC MOTOR SAFETY PRECAUTION

A hydraulic motor must not be used to hold a suspended load. Due to the necessary internal tolerances, all hydraulic motors will experience some degree of creep when a load induced torque is applied to a motor at rest. All applications that require a load to be held must use some form of mechanical brake designed for that purpose.

MOTOR/BRAKE PRECAUTION

Caution! - Impro Fluidtek motor/brakes are intended to operate as static or parking brakes. System circuitry must be designed to bring the load to a stop before applying the brake.

Caution! - Because it is possible for some large displacement motors to overpower the brake, it is critical that the maximum system pressure be limited for these applications. Failure to do so could cause serious injury or death. When choosing a motor/brake for an application, consult the performance chart for the series and displacement chosen for the application to verify that the maximum operating pressure of the system will not allow the motor to produce more torque than the maximum rating of the brake. Also, it is vital that the system relief be set low enough to insure that the motor is not able to overpower the brake.

To ensure proper operation of the brake, a separate case drain back to tank must be used. Use of the internal drain option is not recommended due to the possibility of return line pressure spikes. A simple schematic of a system utilizing a motor/brake is shown on page 5. Although maximum brake release pressure may be used for an application, a 34 bar [500 psi] pressure reducing valve is recommended to promote maximum life for the brake release piston seals. However, if a pressure reducing valve is used in a system which has case drain back pressure, the pressure reducing valve should be set to 34 bar [500 psi] over the expected case pressure to ensure full brake release. To achieve proper brake release operation, it is necessary to bleed out any trapped air and fill brake release cavity and hoses before all connections are tightened. To facilitate this operation, all motor/brakes feature two release ports. One or both of these ports may be used to release the brake in the

OPERATING RECOMMENDATIONS & MOTOR CONNECTIONS

MOTOR/BRAKE PRECAUTION (continued)

unit. Motor/brakes should be configured so that the release ports are near the top of the unit in the installed position.

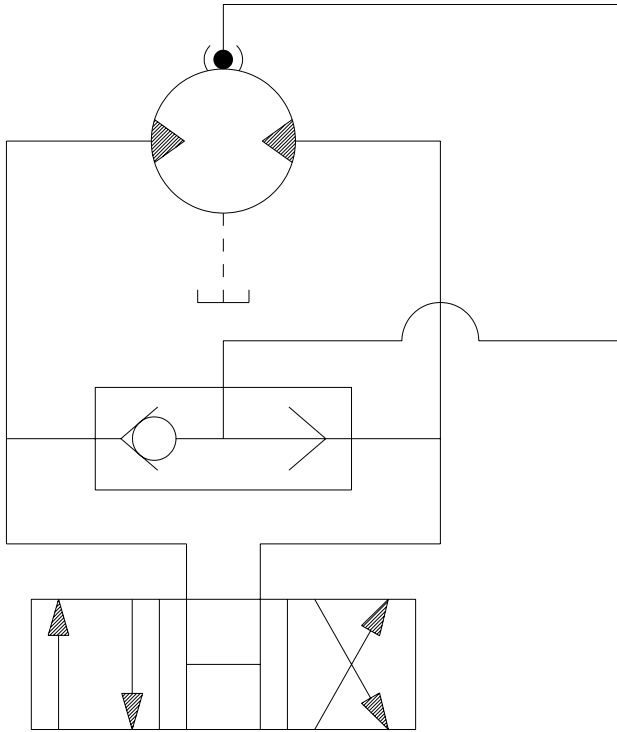

TYPICAL MOTOR/BRAKE SCHEMATIC

Once all system connections are made, one release port must be opened to atmosphere and the brake release line carefully charged with fluid until all air is removed from the line and motor/brake release cavity. When this has been accomplished the port plug or secondary release line must be reinstalled. In the event of a pump or battery failure, an external pressure source may be connected to the brake release port to release the brake, allowing the machine to be moved.

► NOTE: It is vital that all operating recommendations be followed. Failure to do so could result in injury or death.

MOTOR CIRCUITS

There are two common types of circuits used for connecting multiple numbers of motors – series connection and parallel connection.

SERIES CONNECTION

When motors are connected in series, the outlet of one motor is connected to the inlet of the next motor. This allows the full pump flow to go through each motor and provide maximum speed. Pressure and torque are distributed between the motors based on the load each motor is subjected to. The maximum system pressure must be no greater than the maximum inlet pressure of the first motor. The allowable back pressure rating for a motor must also be considered. In some series circuits the motors must have an external case drain connected. A series connection is desirable when it is important for all the motors to run the same speed such as on a long line conveyor.

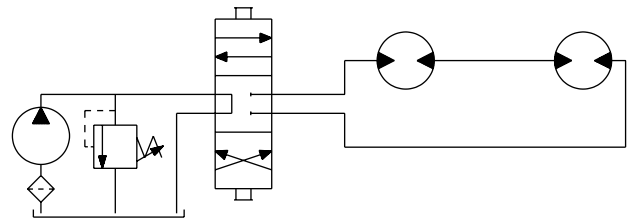

SERIES CIRCUIT

PARALLEL CONNECTION

In a parallel connection all of the motor inlets are connected. This makes the maximum system pressure available to each motor allowing each motor to produce full torque at that pressure. The pump flow is split between the individual motors according to their loads and displacements. If one motor has no load, the oil will take the path of least resistance and all the flow will go to that one motor. The others will not turn. If this condition can occur, a flow divider is recommended to distribute the oil and act as a differential.

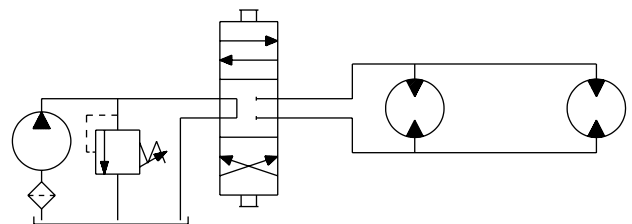

PARALLEL CIRCUIT

► NOTE: The motor circuits shown above are for illustration purposes only. Components and circuitry for actual applications may vary greatly and should be chosen based on the application.

PRODUCT TESTING

Performance testing is the critical measure of a motor's ability to convert flow and pressure into speed and torque. All product testing is conducted using an Impro Fluidtek state of the art test facility. This facility utilizes fully automated test equipment and custom designed software to provide accurate, reliable test data. Test routines are standardized, including test stand calibration and stabilization of fluid temperature and viscosity, to provide consistent data. The example below provides an explanation of the values pertaining to each heading on the performance chart.

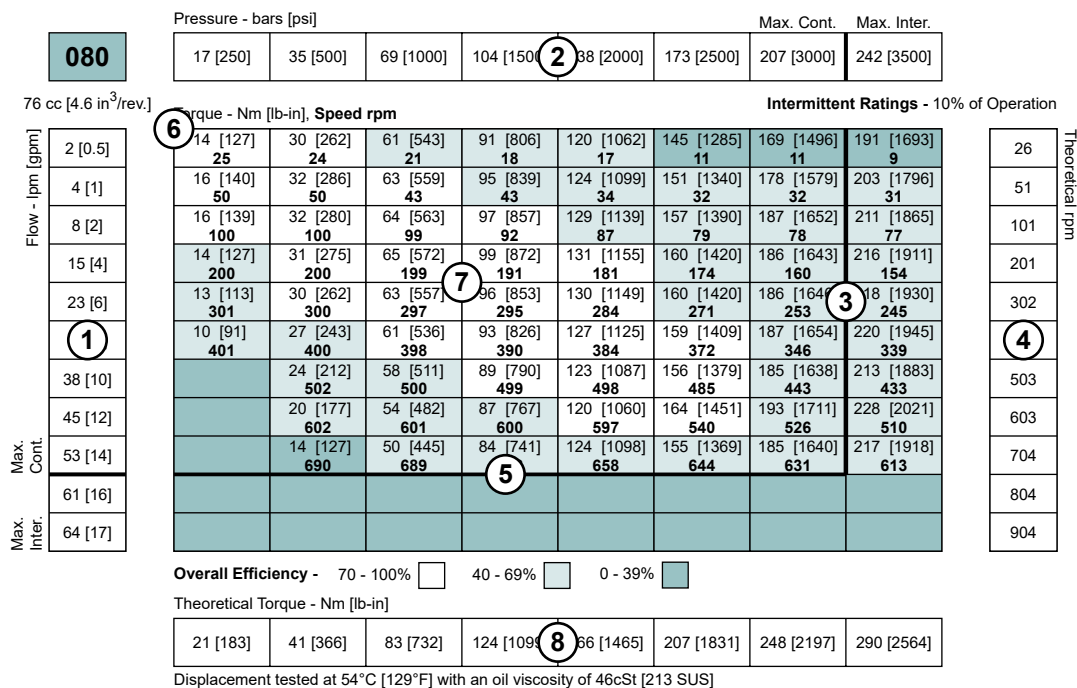

- Flow represents the amount of fluid passing through the motor during each minute of the test.
- Pressure refers to the measured pressure differential between the inlet and return ports of the motor during the test.
- The maximum continuous pressure rating and maximum intermittent pressure rating of the motor are separated by the dark lines on the chart.
- Theoretical RPM represents the RPM that the motor would produce if it were 100% volumetrically efficient. Measured RPM divided by the theoretical RPM give the actual volumetric efficiency of the motor.
- The maximum continuous flow rating and maximum intermittent flow rating of the motor are separated by the dark line on the chart.
- Performance numbers represent the actual torque and speed generated by the motor based on the corresponding input pressure and flow. The numbers on the top row indicate torque as measured in Nm [lb-in], while the bottom number represents the speed of the output shaft.
- Areas within the white shading represent maximum motor efficiencies.
- Theoretical Torque represents the torque that the motor would produce if it were 100% mechanically efficient. Actual torque divided by the theoretical torque gives the actual mechanical efficiency of the motor.

ALLOWABLE BEARING & SHAFT LOADING

This catalog provides curves showing allowable radial loads at points along the longitudinal axis of the motor. They are dimensioned from the mounting flange. Two capacity curves for the shaft and bearings are shown. A vertical line through the centerline of the load drawn to intersect the x-axis intersects the curves at the load capacity of the shaft and of the bearing.

In the example below the maximum radial load bearing rating is between the internal roller bearings illustrated with a solid line. The allowable shaft rating is shown with a dotted line.

The bearing curves for each model are based on laboratory analysis and testing results constructed at Impro Fluidtek. The shaft loading is based on a 3:1 safety factor and 330 Kpsi tensile strength. The allowable load is the lower of the curves at a given point. For instance, one inch in front of the mounting flange the bearing capacity is lower than the shaft capacity. In this case, the bearing is the limiting load. The motor user needs to determine which series of motor to use based on their application knowledge.

ISO 281 RATINGS VS. MANUFACTURERS RATINGS

Published bearing curves can come from more than one type of analysis. The ISO 281 bearing rating is an international standard for the dynamic load rating of roller bearings. The rating is for a set load at a speed of 33 1/3 RPM for 500 hours (1 million revolutions). The standard was established to allow consistent comparisons of similar bearings between manufacturers. The ISO 281 bearing ratings are based solely on the physical characteristics of the bearings, removing any manufacturers specific safety factors or empirical data that influences the ratings.

Manufacturers' ratings are adjusted by diverse and systematic laboratory investigations, checked constantly with feedback from practical experience. Factors taken into account that affect bearing life are material, lubrication, cleanliness of the lubrication, speed, temperature, magnitude of the load and the bearing type.

The operating life of a bearing is the actual life achieved by the bearing and can be significantly different from the calculated life. Comparison with similar applications is the most accurate method for bearing life estimations.

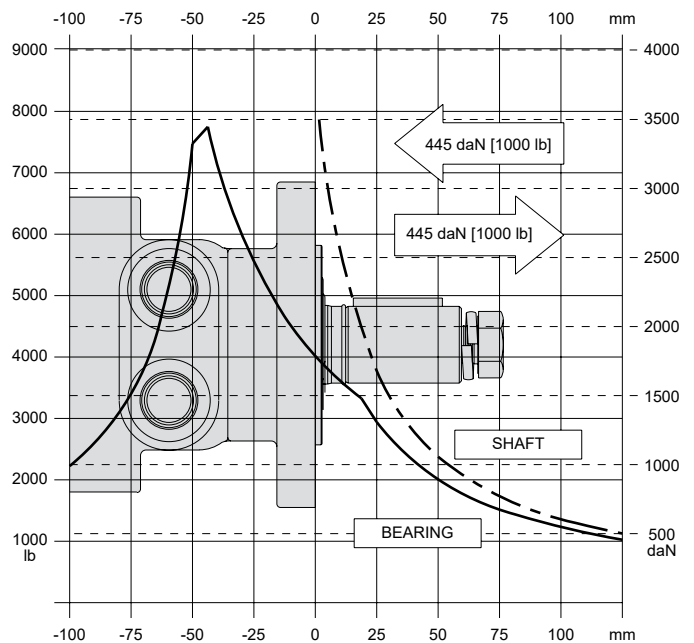

EXAMPLE LOAD RATING FOR MECHANICALLY RETAINED NEEDLE ROLLER BEARINGS

Bearing Life $L_{10} = (C/P)^p [10^6 \text{ revolutions}]$

L_{10} = nominal rating life

C = dynamic load rating

P = equivalent dynamic load

Life Exponent $P = 10/3$ for needle bearings

BEARING LOAD MULTIPLICATION FACTOR TABLE			
RPM	FACTOR	RPM	FACTOR
50	1.23	500	0.62
100	1.00	600	0.58
200	0.81	700	0.56
300	0.72	800	0.50
400	0.66		

VEHICLE DRIVE CALCULATIONS

When selecting a wheel drive motor for a mobile vehicle, a number of factors concerning the vehicle must be taken into consideration to determine the required maximum motor RPM, the maximum torque required and the maximum load each motor must support. The following sections contain the necessary equations to determine this criteria. An example is provided to illustrate the process.

Sample application (vehicle design criteria)

vehicle description..... 4 wheel vehicle
 vehicle drive.....2 wheel drive
 GVW1,500lbs.
 weight over each drive wheel 425 lbs.
 rolling radius of tires 16 in.
 desired acceleration0-5 mph in 10 sec.
 top speed..... 5 mph
 gradability.....20%
 worst working surface..... poor asphalt

To determine maximum motor speed

$$\text{RPM} = \frac{2.65 \times \text{KPH} \times G}{r_m} \quad \text{RPM} = \frac{168 \times \text{MPH} \times G}{r_i}$$

Where:

MPH = max. vehicle speed (miles/hr)
 KPH = max. vehicle speed (kilometers/hr)
 r_i = rolling radius of tire (inches)
 G = gear reduction ratio (if none, G = 1)
 r_m = rolling radius of tire (meters)

Example $\text{RPM} = \frac{168 \times 5 \times 1}{16} = 52.5$

To determine maximum torque requirement of motor

To choose a motor(s) capable of producing enough torque to propel the vehicle, it is necessary to determine the Total Tractive Effort (TE) requirement for the vehicle. To determine the total tractive effort, the following equation must be used:

$$\text{TE} = \text{RR} + \text{GR} + \text{FA} + \text{DP} \text{ (lbs or N)}$$

Where:

TE = Total tractive effort
 RR = Force necessary to overcome rolling resistance
 GR = Force required to climb a grade
 FA = Force required to accelerate
 DP = Drawbar pull required

The components for this equation may be determined using the following steps:

Step One: Determine Rolling Resistance

Rolling Resistance (RR) is the force necessary to propel a vehicle over a particular surface. It is recommended that the worst possible surface type to be encountered by the vehicle be factored into the equation.

$$\text{RR} = \frac{\text{GVW}}{1000} \times R \text{ (lb or N)}$$

Where:

GVW = gross (loaded) vehicle weight (lb or kg)
 R = surface friction (value from Table 1)

Example $\text{RR} = \frac{1500}{1000} \times 22 \text{ lbs} = 33 \text{ lbs}$

Table 1

Rolling Resistance	
Concrete (excellent).....	10
Concrete (good).....	15
Concrete (poor).....	20
Asphalt (good).....	12
Asphalt (fair).....	17
Asphalt (poor).....	22
Macadam (good).....	15
Macadam (fair).....	22
Macadam (poor).....	37
Cobbles (ordinary).....	55
Cobbles (poor).....	37
Snow (2 inch).....	25
Snow (4 inch).....	37
Dirt (smooth).....	25
Dirt (sandy).....	37
Mud.....	37 to 150
Sand (soft).....	60 to 150
Sand (dune).....	160 to 300

Step Two: Determine Grade Resistance

Grade Resistance (GR) is the amount of force necessary to move a vehicle up a hill or "grade." This calculation must be made using the maximum grade the vehicle will be expected to climb in normal operation.

To convert incline degrees to % Grade:

$$\% \text{ Grade} = [\tan \text{ of angle (degrees)}] \times 100$$

$$\text{GR} = \frac{\% \text{ Grade}}{100} \times \text{GVW} \text{ (lb or N)}$$

Example $\text{GR} = \frac{20}{100} \times 1500 \text{ lbs} = 300 \text{ lbs}$

VEHICLE DRIVE CALCULATIONS

Step Three: Determine Acceleration Force

Acceleration Force (FA) is the force necessary to accelerate from a stop to maximum speed in a desired time.

$$FA = \frac{MPH \times GVW \text{ (lb)}}{22 \times t} \qquad FA = \frac{KPH \times GVW \text{ (N)}}{35.32 \times t}$$

Where:

t = time to maximum speed (seconds)

Example $FA = \frac{5 \times 1500 \text{ lbs}}{22 \times 10} = 34 \text{ lbs}$

Step Four: Determine Drawbar Pull

Drawbar Pull (DP) is the additional force, if any, the vehicle will be required to generate if it is to be used to tow other equipment. If additional towing capacity is required for the equipment, repeat steps one through three for the towable equipment and sum the totals to determine DP.

Step Five: Determine Total Tractive Effort

The Tractive Effort (TE) is the sum of the forces calculated in steps one through three above. On low speed vehicles, wind resistance can typically be neglected. However, friction in drive components may warrant the addition of 10% to the total tractive effort to insure acceptable vehicle performance.

$$TE = RR + GR + FA + DP \text{ (lb or N)}$$

Example $TE = 33 + 300 + 34 + 0 \text{ (lbs)} = 367 \text{ lbs}$

Step Six: Determine Motor Torque

The Motor Torque (T) required per motor is the Total Tractive Effort divided by the number of motors used on the machine. Gear reduction is also factored into account in this equation.

$$T = \frac{TE \times ri}{M \times G} \text{ lb-in per motor} \qquad T = \frac{TE \times rm}{M \times G} \text{ Nm per motor}$$

Where:

M = number of driving motors

Example $T = \frac{367 \times 16}{2 \times 1} \text{ lb-in/motor} = 2936 \text{ lb-in}$

Step Seven: Determine Wheel Slip

To verify that the vehicle will perform as designed in regards to tractive effort and acceleration, it is necessary to calculate wheel slip (TS) for the vehicle. In special cases, wheel slip may actually be desirable to prevent hydraulic system overheating and component breakage should the vehicle become stalled.

$$TS = \frac{W \times f \times ri}{G} \qquad TS = \frac{W \times f \times rm}{G}$$

(lb-in per motor) (N-m per motor)

Where:

f = coefficient of friction (see table 2)

W = loaded vehicle weight over driven wheel (lb or N)

Example $TS = \frac{425 \times .06 \times 16}{1} \text{ lb-in/motor} = 4080 \text{ lbs}$

Table 2

Coefficient of friction (f)	
Steel on steel.....	0.3
Rubber tire on dirt.....	0.5
Rubber tire on a hard surface	0.6 - 0.8
Rubber tire on cement.....	0.7

To determine radial load capacity requirement of motor

When a motor used to drive a vehicle has the wheel or hub attached directly to the motor shaft, it is critical that the radial load capabilities of the motor are sufficient to support the vehicle. After calculating the Total Radial Load (RL) acting on the motors, the result must be compared to the bearing/shaft load charts for the chosen motor to determine if the motor will provide acceptable load capacity and life.

$$RL = \sqrt{W^2 + \left(\frac{T}{ri}\right)^2} \text{ lb} \qquad RL = \sqrt{W^2 + \left(\frac{T}{rm}\right)^2} \text{ kg}$$

Example $RL = \sqrt{425^2 + \left(\frac{2936}{16}\right)^2} = 463 \text{ lbs}$

Once the maximum motor RPM, maximum torque requirement, and the maximum load each motor must support have been determined, these figures may then be compared to the motor performance charts and to the bearing load curves to choose a series and displacement to fulfill the motor requirements for the application.

INDUCED SIDE LOAD

In many cases, pulleys or sprockets may be used to transmit the torque produced by the motor. Use of these components will create a torque induced side load on the motor shaft and bearings. It is important that this load be taken into consideration when choosing a motor with sufficient bearing and shaft capacity for the application.

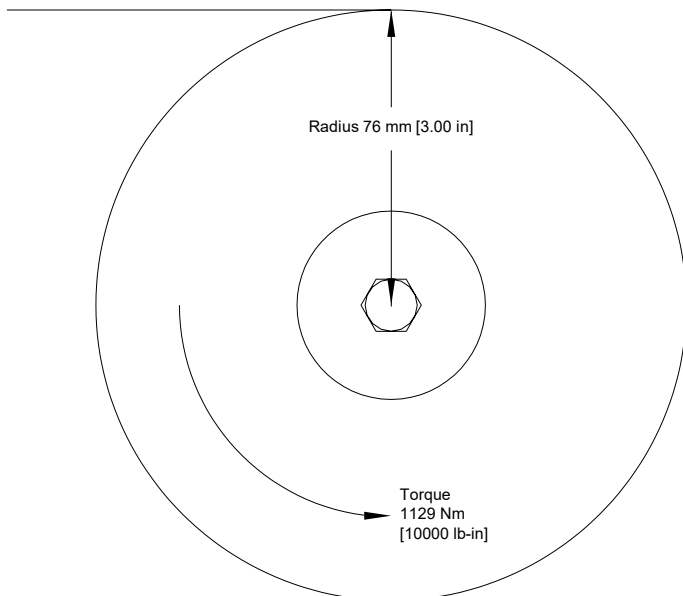

To determine the side load, the motor torque and pulley or sprocket radius must be known. Side load may be calculated using the formula below. The distance from the pulley/sprocket centerline to the mounting flange of the motor must also be determined. These two figures may then be compared to the bearing and shaft load curve of the desired motor to determine if the side load falls within acceptable load ranges.

$$\text{Side Load} = \frac{\text{Torque}}{\text{Radius}}$$

$$\text{Side Load} = 14855 \text{ Nm [3333 lbs]}$$

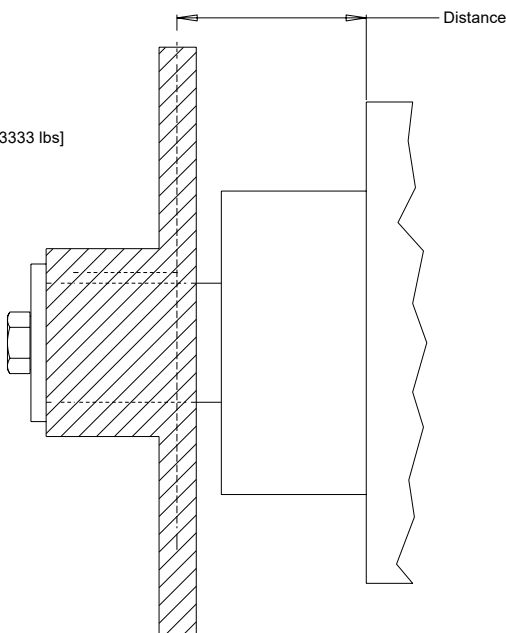

HYDRAULIC EQUATIONS

Multiplication Factor	Abbrev.	Prefix
10 ¹²	T	tera
10 ⁹	G	giga
10 ⁶	M	mega
10 ³	K	kilo
10 ²	h	hecto
10 ¹	da	deka
10 ⁻¹	d	deci
10 ⁻²	c	centi
10 ⁻³	m	milli
10 ⁻⁶	u	micro
10 ⁻⁹	n	nano
10 ⁻¹²	p	pico
10 ⁻¹⁵	f	femto
10 ⁻¹⁸	a	atto

Theo. Speed (RPM) =

$$\frac{1000 \times \text{LPM}}{\text{Displacement (cm}^3\text{/rev)}} \quad \text{or} \quad \frac{231 \times \text{GPM}}{\text{Displacement (in}^3\text{/rev)}}$$

Theo. Torque (lb-in) =

$$\frac{\text{Bar} \times \text{Disp. (cm}^3\text{/rev)}}{20 \pi} \quad \text{or} \quad \frac{\text{PSI} \times \text{Displacement (in}^3\text{/rev)}}{6.28}$$

Power In (HP) =

$$\frac{\text{Bar} \times \text{LPM}}{600} \quad \text{or} \quad \frac{\text{PSI} \times \text{GPM}}{1714}$$

Power Out (HP) =

$$\frac{\text{Torque (Nm)} \times \text{RPM}}{9543} \quad \text{or} \quad \frac{\text{Torque (lb-in)} \times \text{RPM}}{63024}$$

SHAFT NUT INFORMATION

35MM TAPERED SHAFTS
M24 x 1.5 Thread

A Slotted Nut

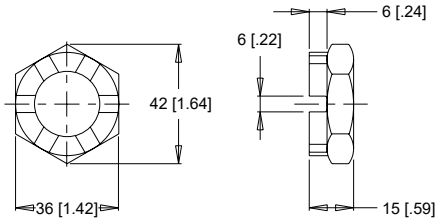

Torque Specifications: 32.5 daNm [240 ft.lb.]

PRECAUTION

The tightening torques listed with each nut should only be used as a guideline. Hubs may require higher or lower tightening torque depending on the material. Consult the hub manufacturer to obtain recommended tightening torque. To maximize torque transfer from the shaft to the hub, and to minimize the potential for shaft breakage, a hub with sufficient thickness must fully engage the taper length of the shaft.

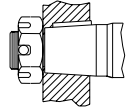

incorrect

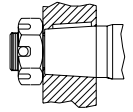

correct

1" TAPERED SHAFTS
3/4-28 Thread

A Slotted Nut

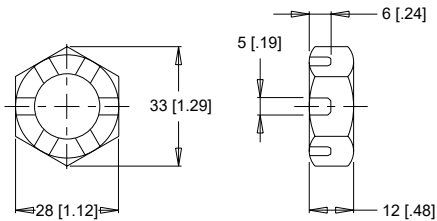

Torque Specifications: 20 - 23 daNm [150 - 170 ft.lb.]

B Lock Nut

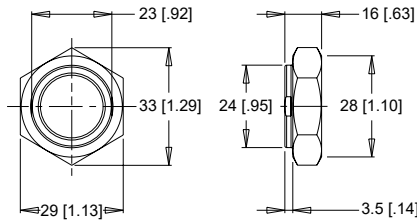

Torque Specifications: 24 - 27 daNm [180 - 200 ft.lb.]

C Solid Nut

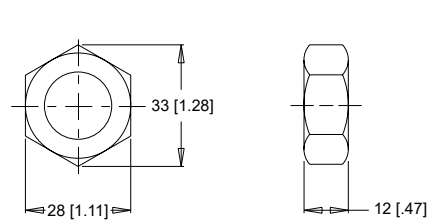

Torque Specifications: 20 - 23 daNm [150 - 170 ft.lb.]

1-1/4" TAPERED SHAFTS
1-20 Thread

A Slotted Nut

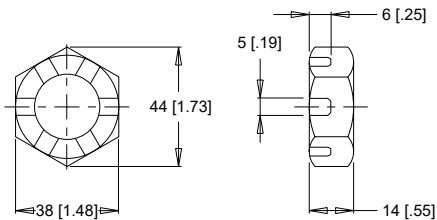

Torque Specifications: 38 daNm [280 ft.lb.] Max.

B Lock Nut

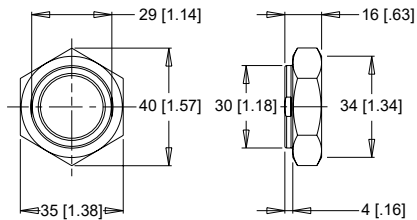

Torque Specifications: 33 - 42 daNm [240 - 310 ft.lb.]

C Solid Nut

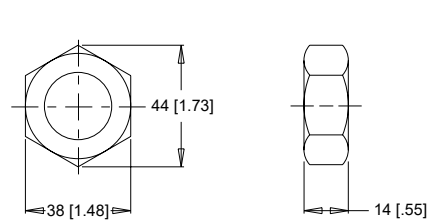

Torque Specifications: 38 daNm [280 ft.lb.] Max.

1-3/8" & 1-1/2" TAPERED SHAFTS
1 1/8-18 Thread

A Slotted Nut

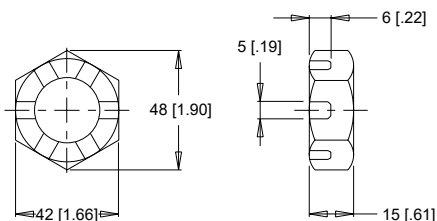

Torque Specifications: 41 - 54 daNm [300 - 400 ft.lb.]

B Lock Nut

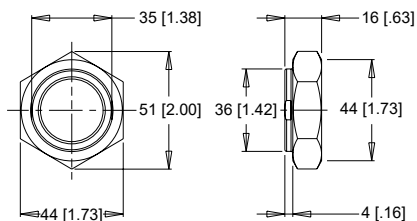

Torque Specifications: 34 - 48 daNm [250 - 350 ft.lb.]

C Solid Nut

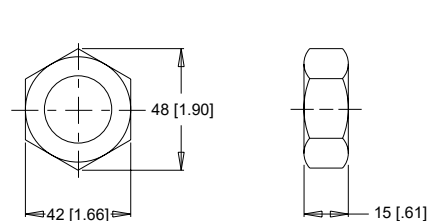

Torque Specifications: 41 - 54 daNm [300 - 400 ft.lb.]

SPEED SENSORS

Impro Fluidtek offers both single and dual element speed sensor options providing a number of benefits to users by incorporating the latest advancements in sensing technology and materials. The single element sensors provide 50 pulses per revolution with the dual element providing 100 pulses per revolution.” Higher resolution is especially beneficial for slow speed applications, where more information is needed for smooth and accurate control. The dual sensor option also provides a direction signal allowing end-users to monitor the direction of shaft rotation.

Unlike competitive designs that breach the high pressure area of the motor to add the sensor, the Impro Fluidtek speed sensor option utilizes an add-on flange to locate all sensor components outside the high pressure operating environment. This eliminates the potential leak point common to competitive designs. Many improvements were made to the sensor flange including changing the material from cast iron to acetal resin, incorporating a Buna-N shaft seal internal to the flange, and providing a grease zerk, which allows the user to fill the sensor cavity with grease. These improvements enable the flange to withstand the rigors of harsh environments.

Another important feature of the new sensor flange is that it is self-centering, which allows it to remain concentric to the magnet rotor. This produces a consistent mounting location for the new sensor module, eliminating the need to adjust

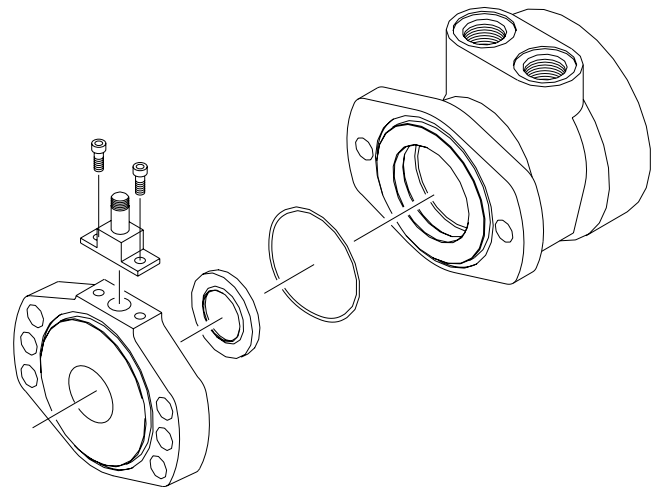

the air gap between the sensor and magnet rotor. The o-ring sealed sensor module attaches to the sensor flange with two small screws, allowing the sensor to be serviced or upgraded in the field in under one minute. This feature is especially valuable for mobile applications where machine downtime is costly. The sensor may also be serviced without exposing the hydraulic circuit to the atmosphere. Another advantage of the self-centering flange is that it allows users to rotate the sensor to a location best suited to their application. This feature is not available on competitive designs, which fix the sensor in one location in relationship to the motor mounting flange.

FEATURES / BENEFITS

- Grease fitting allows sensor cavity to be filled with grease for additional protection.
- Internal extruder seal protects against environmental elements.
- M12 or weatherpack connectors provide installation flexibility.
- Dual element sensor provides up to 100 pulses per revolution and directional sensing.
- Modular sensor allows quick and easy servicing.
- Acetal resin flange is resistant to moisture, chemicals, oils, solvents and greases.
- Self-centering design eliminates need to set magnet-to-sensor air gap.
- Protection circuitry

SENSOR OPTIONS

Z - 4-pin M12 male connector

This option has 50 pulses per revolution on all series. This option will not detect direction.

Y - 3-pin male weatherpack connector*

This option has 50 pulses per revolution on all series. This option will not detect direction.

X - 4-pin M12 male connector

This option has 100 pulses per revolution on all series. This option will detect direction.

W - 4-pin male weatherpack connector*

This option has 100 pulses per revolution on all series. This option will detect direction.

*These options include a 610mm [2 ft] cable.

SPEED SENSORS

SINGLE ELEMENT SENSOR - Y & Z

Supply voltages..... 7.5-24 Vdc
 Maximum output off voltage..... V
 Maximum continuous output current..... < 25 ma
 Signal levels (low, high)..... 0.8 to supply voltage
 Operating Temp-30°C to 83°C [-22°F to 181°F]

DUAL ELEMENT SENSOR - X & W

Supply voltages..... 7.5-18 Vdc
 Maximum output off voltage..... V
 Maximum continuous output current..... < 20 ma
 Signal levels (low, high)..... 0.8 to supply voltage
 Operating Temp-30°C to 83°C [-22°F to 181°F]

SENSOR CONNECTORS

Z Option

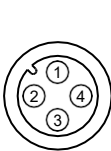

PIN		
1	positive	brown or red
2	n/a	white
3	negative	blue
4	pulse out	black

X Option

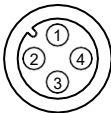

PIN		
1	positive	brown or red
2	direction out	white
3	negative	blue
4	pulse out	black

Y Option

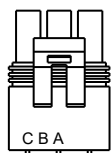

PIN		
A	positive	brown or red
B	negative	blue
C	pulse out	black
D	n/a	white

W Option

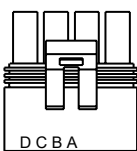

PIN		
A	positive	brown or red
B	negative	blue
C	pulse out	black
D	direction out	white

PROTECTION CIRCUITRY

The single element sensor has been improved and incorporates protection circuitry to avoid electrical damage caused by:

- reverse battery protection
- overvoltage due to power supply spikes and surges (60 Vdc max.)
- power applied to the output lead

The protection circuit feature will help “save” the sensor from damage mentioned above caused by:

- faulty installation wiring or system repair
- wiring harness shorts/opens due to equipment failure or harness damage resulting from accidental conditions (i.e. severed or grounded wire, ice, etc.)
- power supply spikes and surges caused by other electrical/electronic components that may be intermittent or damaged and “loading down” the system.

While no protection circuit can guarantee against any and all fault conditions. The single element sensor from Impro Fluidtek with protection circuitry is designed to handle potential hazards commonly seen in real world applications.

Unprotected versions are also available for operation at lower voltages down to 4.5V.

FREE TURNING ROTOR

The ‘AC’ option or “Free turning” option refers to a specially prepared rotor assembly. This rotor assembly has increased clearance between the rotor tips and rollers allowing it to turn more freely than a standard rotor assembly. For spool valve motors, additional clearance is also provided between the shaft and housing bore. The ‘AC’ option is available for all motor series and displacements.

There are several applications and duty cycle conditions where ‘AC’ option performance characteristics can be beneficial. In continuous duty applications that require high flow/high rpm operation, the benefits are twofold. The additional clearance helps to minimize internal pressure drop at high flows. This clearance also provides a thicker oil film at metal to metal contact areas and can help extend the life of the motor in high rpm or even over speed conditions. The ‘AC’ option should be considered for applications that require continuous operation above 57 LPM [15 GPM] and/or 300 rpm. Applications that are subject to pressure spikes due to frequent reversals or shock loads can also benefit by specifying the ‘AC’ option. The additional clearance serves to act as a buffer against spikes, allowing them to be bypassed through the motor rather than being absorbed and transmitted through the drive link to the output shaft. The trade-off for achieving these benefits is a slight loss of volumetric efficiency at high pressures.

INTERNAL DRAIN

The internal drain is standard on all WD, WP, WR, and WS360. Typically, a separate drain line must be installed to direct case leakage of the motor back to the reservoir when using, WS365/366. However, the internal drain option eliminates the need for a separate drain line through the installation of two check valves in the motor. This simplifies plumbing requirements for the motor.

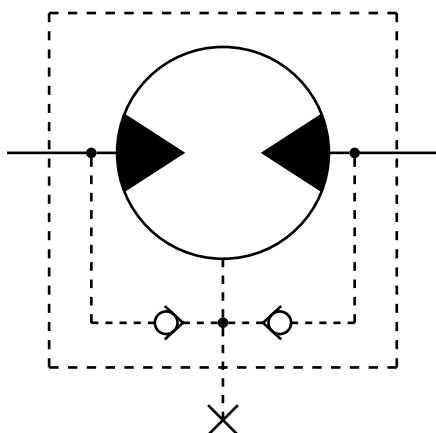

The two check valves connect the case area of the motor to each port of the endcover. During normal motor operation, pressure in the input and return lines of the motor close the check valves. However, when the pressure in the case of the motor is greater than that of the return line, the check valve between the case and low pressure line opens, allowing the case leakage to flow into the return line. Since the operation of the check valves is dependent upon a pressure differential, the internal drain option operates in either direction of motor rotation.

Although this option can simplify many motor installations, precautions must be taken to insure that return line pressure remains below allowable levels (see table below) to insure proper motor operation and life. If return line pressure is higher than allowable, or experiences pressure spikes, this pressure may feed back into the motor, possibly causing catastrophic seal failure. Installing motors with internal drains in series is not recommended unless overall pressure drop over all motors is below the maximum allowable backpressure as listed in the chart below. If in doubt, contact your authorized Impro Fluidtek representative.

MAXIMUM ALLOWABLE BACK PRESSURE		
Series	Cont. bar [psi]	Inter. bar [psi]
Brakes	34 [500]	34 [500]

HYDRAULIC DECLUTCH

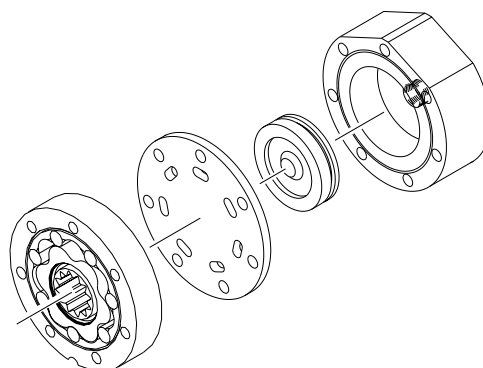

The declutch or 'AE' option, available on the RE and CE Series motors, has been specifically designed for applications requiring the motor to have the ability to "freewheel" when not pressurized. By making minor changes to internal components, the torque required to turn the output shaft is minimal. Selection of this option allows freewheeling speeds up to 1,000 RPM* depending on the displacement of the motor and duty cycle of the application.

To enable the motor to perform this function, the standard rotor assembly is replaced with a freeturn rotor assembly. Next, the standard balance plate and endcover is replaced with a special wear plate and ported endcover. The wear plate features seven holes that connect the stator pockets to each other. The ported endcover features a movable piston capable of sealing the seven holes in the wear plate.

When standard motor function is required, pressure is supplied to the endcover port, moving the piston against the wear plate. This action seals the seven holes allowing the motor to function as normal. However, when pressure is removed from the endcover port, the pressure created by the turning rotor assembly pushes the piston away from the wear plate, opening the rotor pockets to each other. In this condition, oil may circulate freely within the rotor and endcover assemblies, allowing the rotor assembly to rotate freely within the motor.

This option is especially useful in applications ranging from winch drives to towable wheel drives. Depending on the valves and hydraulic circuitry, operation of the freewheel function may be manually or automatically selected. A basic schematic is shown to the right.

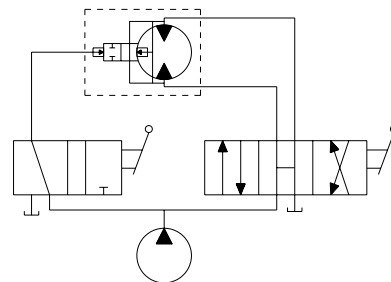

► The 1,000 RPM rating was based on smaller displacement options with forced flow flushing through the motor to provide cooling.

VALVE CAVITY

The valve cavity option provides a cost effective way to incorporate a variety of cartridge valves integral to the motor. The valve cavity is a standard 10 series 2-way cavity that accepts numerous cartridge valves, including over-running check valves, relief cartridges, flow control valves, pilot operated check fuses, and high pressure shuttle valves. Installation of a relief cartridge into the cavity provides an extra margin of safety for applications encountering frequent pressure spikes. Relief cartridges from 69 to 207 bar [1000 to 3000 psi] may also be factory installed.

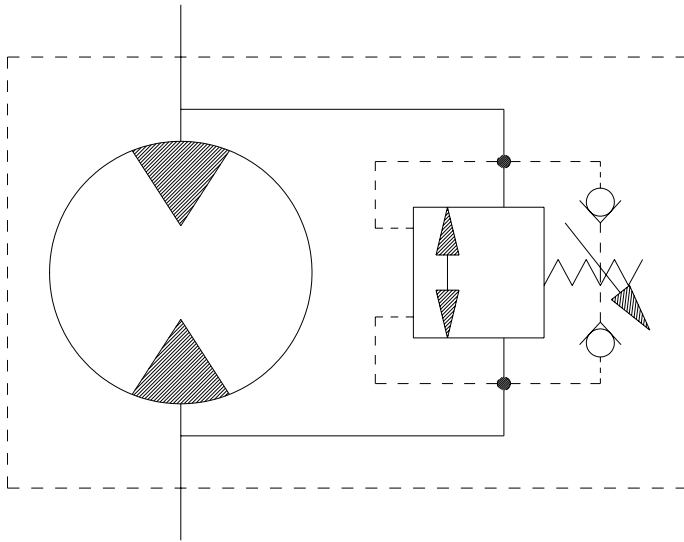

For basic systems with fixed displacement pumps, either manual or motorized flow control valves may be installed into the valve cavity to provide a simple method for controlling motor speed. It is also possible to incorporate the speed sensor option and a programmable logic controller with a motorized flow control valve to create a closed loop, fully automated speed control system. For motors with internal brakes, a shuttle valve cartridge may be installed into the cavity to provide a simple, fully integrated method for supplying release pressure to the pilot line to actuate an integral brake. To discuss other alternatives for the valve cavity option, contact an authorized Impro Fluidtek distributor.

SLINGER SEAL

Slinger seals are available on select series offered by Impro Fluidtek. Slinger seals offer extended shaft/shaft seal protection by prevented a buildup of material around the circumference of the shaft which can lead to premature shaft seal failures. The Impro Fluidtek slinger seals are designed to be larger in diameter than competitive products, providing greater surface speed and 'slinging action'.

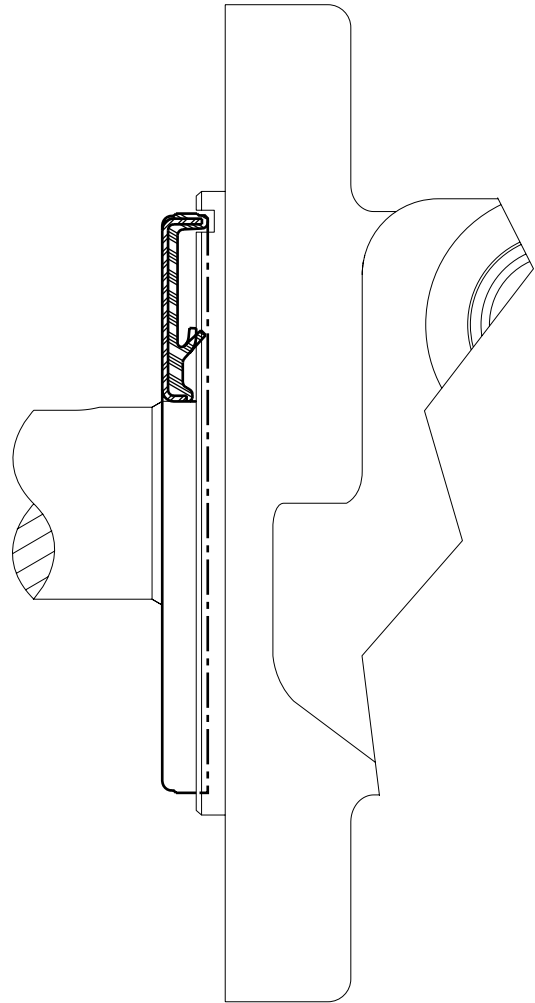

Slinger seals are also available on 4-hole flange mounts on select series. Contact a Impro Fluidtek Customer Service Representative for additional information.

OVERVIEW

RE Series motors offer the perfect compromise between price and performance by producing work horse power at a reasonable cost. Although these motors perform well in a wide range of applications, they are especially suited for low flow, high pressure applications. During startup, pressure causes the balance plate to flex toward the rotor, vastly improving volumetric efficiency. As the motor reaches operating pressure, the balance plate relaxes, allowing the rotor to turn freely which translates into higher mechanical efficiencies. Transmitting this power to the output shaft is the most durable drive link in its class. Four bearing options, combined with standard mounting flanges and output shafts, allow the motor to be configured to suit nearly any application.

FEATURES / BENEFITS

- High Pressure Shaft Seal offers superior seal life and performance and eliminates need for case drain.
- Three Bearing Options allow load carrying capability of motor to be matched to application.
- Heavy-Duty Drive Link is the most durable in its class and receives full flow lubrication to provide long life.
- Valve-In-Rotor Design provides cost effective, efficient distribution of oil and reduces overall motor length.
- Pressure-Compensated Balance Plate improves volumetric efficiency at low flows and high pressure.

TYPICAL APPLICATIONS

Medium-duty wheel drives, augers, mixers, winch drives, swing drives, grapple heads, feed rollers, broom drives and more

SPECIFICATIONS

CODE	Displacement cm ³ [in ³ /rev]	Max. Speed rpm		Max. Flow lpm [gpm]		Max. Torque Nm [lb-in]		Max. Pressure bar [psi]		
		cont.	inter.	cont.	inter.	cont.	inter.	cont.	inter.	peak
120	121 [7.4]	360	490	45 [12]	61 [16]	327 [2900]	383 [3400]	207 [3000]	241 [3500]	276 [4000]
160	162 [9.9]	370	470	61 [16]	76 [20]	475 [4200]	542 [4800]	207 [3000]	241 [3500]	276 [4000]
200	204 [12.4]	300	370	68 [18]	83 [22]	542 [4800]	633 [5600]	207 [3000]	241 [3500]	276 [4000]
230	232 [14.2]	260	320	68 [18]	83 [22]	644 [5700]	712 [6300]	207 [3000]	241 [3500]	276 [4000]
260	261 [15.9]	260	350	76 [20]	91 [24]	712 [6300]	791 [7000]	207 [3000]	241 [3500]	276 [4000]
300	300 [18.3]	250	320	83 [22]	95 [25]	825 [7300]	938 [8300]	207 [3000]	241 [3500]	276 [4000]
350	348 [21.2]	220	270	83 [22]	95 [25]	921 [8150]	1045 [9250]	207 [3000]	241 [3500]	276 [4000]
375	375 [22.8]	200	250	76 [20]	91 [24]	1006 [8900]	1158 [10250]	207 [3000]	241 [3500]	276 [4000]
470	465 [28.3]	160	200	76 [20]	91 [24]	1096 [9700]	1184 [10475]	172 [2500]	189 [2750]	207 [3000]
540	536 [32.7]	140	170	76 [20]	91 [24]	983 [8700]	1243 [11000]	138 [2000]	173 [2500]	207 [3000]
620	631 [38.5]	120	150	76 [20]	91 [24]	1014 [8976]	1291 [11421]	121 [1750]	155 [2250]	173 [2500]
750	748 [45.6]	100	130	76 [20]	91 [24]	1062 [9400]	1237 [10950]	103 [1500]	121 [1750]	138 [2000]

► Performance data is typical. Performance of production units varies slightly from one motor to another. Running at intermittent ratings should not exceed 10% of every minute of operation.

SERIES DESCRIPTIONS

505/506 - Hydraulic Motor
Standard

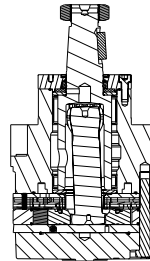

530/531 - Hydraulic Motor
With Heavy Duty Bearing

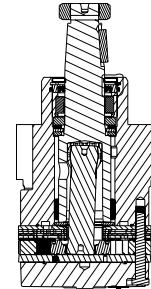

535/536 - Hydraulic Motor
Compact, Heavy Duty Bearing

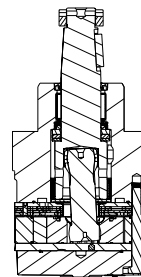

DISPLACEMENT PERFORMANCE

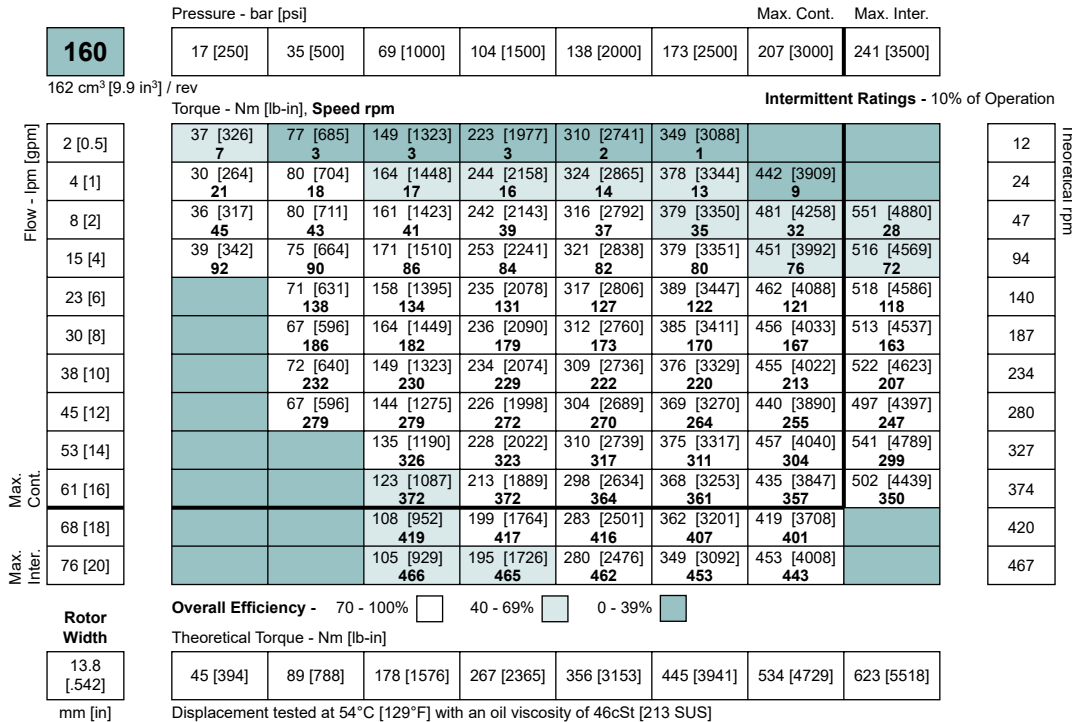
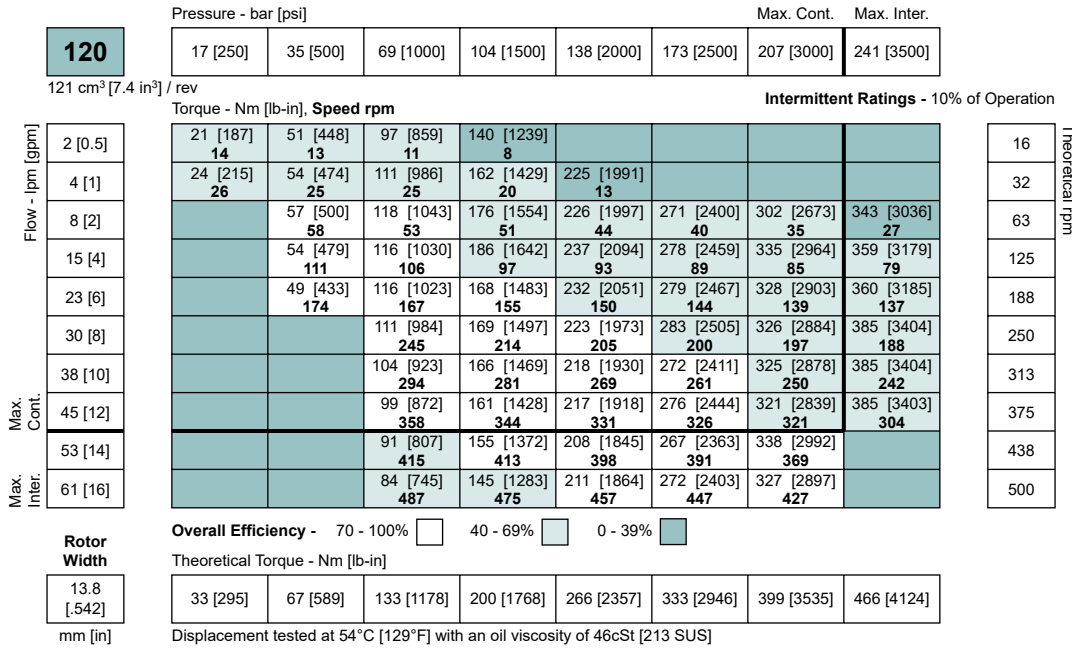

► Performance data is typical. Performance of production units varies slightly from one motor to another. Operating at maximum continuous pressure and maximum continuous flow simultaneously is not recommended. For additional information on product testing please refer to page 6.

DISPLACEMENT PERFORMANCE

		Pressure - bar [psi]						Max. Cont.	Max. Inter.
200		17 [250]	35 [500]	69 [1000]	104 [1500]	138 [2000]	173 [2500]	207 [3000]	241 [3500]
204 cm ³ [12.4 in ³] / rev									
		Torque - Nm [lb-in], Speed rpm						Intermittent Ratings - 10% of Operation	
Flow - lpm [gpm]	2 [0.5]	40 [358] 7	91 [808] 4	133 [1181] 4	294 [2602] 4	375 [3323] 3			10
	4 [1]	43 [376] 16	85 [753] 13	200 [1769] 12	276 [2442] 11	373 [3304] 10	442 [3915] 9	526 [4656] 6	19
	8 [2]	44 [385] 34	93 [851] 31	195 [1727] 29	299 [2646] 27	374 [3311] 27	461 [4079] 25	542 [4792] 23	38
	15 [4]	39 [347] 72	94 [834] 69	198 [1752] 67	305 [2701] 63	401 [3549] 60	477 [4222] 58	544 [4818] 55	75
	23 [6]		82 [724] 111	191 [1694] 109	284 [2518] 107	389 [3446] 103	463 [4098] 100	553 [4894] 99	112
	30 [8]		80 [704] 148	188 [1661] 145	285 [2518] 141	402 [3556] 136	458 [4053] 134	543 [4802] 130	150
	38 [10]		66 [581] 185	180 [1592] 181	276 [2445] 176	364 [3224] 173	458 [4051] 170	535 [4737] 164	187
	45 [12]			165 [1462] 221	261 [2312] 214	362 [3200] 210	450 [3982] 207	535 [4731] 198	224
	53 [14]			150 [1328] 257	273 [2413] 256	368 [3253] 247	449 [3975] 244	558 [4936] 241	261
	61 [16]			134 [1183] 296	253 [2242] 292	335 [2969] 284	435 [3850] 277	524 [4639] 273	299
Max. Cont.	68 [18]		121 [1068] 334	232 [2056] 330	339 [3003] 327	416 [3686] 320	512 [4532] 313	599 [5299] 308	336
Max. Inter.	76 [20]		110 [970] 372	206 [1823] 372	308 [2725] 365	401 [3552] 357	507 [4484] 352		373
	83 [22]			191 [1689] 407	285 [2520] 403	379 [3353] 397	486 [4303] 388		410
Overall Efficiency - 70 - 100% <input type="checkbox"/> 40 - 69% <input type="checkbox"/> 0 - 39% <input checked="" type="checkbox"/>									
Rotor Width									
17.3 [.682]									
mm [in]									
		Theoretical Torque - Nm [lb-in]							
		56 [494]	112 [987]	223 [1975]	335 [2962]	446 [3949]	558 [4936]	669 [5924]	781 [6911]
Displacement tested at 54°C [129°F] with an oil viscosity of 46cSt [213 SUS]									

		Pressure - bar [psi]						Max. Cont.	Max. Inter.
230		17 [250]	35 [500]	69 [1000]	104 [1500]	138 [2000]	173 [2500]	207 [3000]	241 [3500]
233 cm ³ [14.2 in ³] / rev									
		Torque - Nm [lb-in], Speed rpm						Intermittent Ratings - 10% of Operation	
Flow - lpm [gpm]	2 [0.5]	45 [397] 6	92 [813] 4	184 [1628] 3	293 [2590] 2	375 [3323] 1			9
	4 [1]	48 [429] 14	101 [890] 12	223 [1972] 11	316 [2793] 11	414 [3660] 9	493 [4366] 7	560 [4955] 4	17
	8 [2]	51 [453] 30	105 [926] 27	215 [1899] 25	329 [2911] 25	425 [3760] 23	524 [4637] 20	618 [5468] 17	33
	15 [4]	43 [384] 63	108 [960] 59	209 [1851] 55	326 [2884] 54	435 [3846] 52	539 [4771] 47	655 [5799] 42	66
	23 [6]		102 [603] 93	213 [1889] 88	339 [3001] 85	428 [3789] 82	536 [4747] 77	628 [5559] 73	98
	30 [8]		89 [789] 127	207 [1830] 122	316 [2793] 120	425 [3762] 115	521 [4612] 110	639 [5653] 107	131
	38 [10]		78 [690] 161	198 [1750] 157	311 [2752] 151	436 [3856] 148	527 [4660] 143	612 [5420] 140	163
	45 [12]			189 [1669] 191	296 [2624] 186	425 [3764] 182	510 [4517] 176	599 [5304] 170	196
	53 [14]			177 [1565] 224	293 [2596] 216	388 [3434] 214	495 [4384] 208	587 [5197] 205	228
	61 [16]			150 [1326] 256	272 [2408] 255	397 [3509] 249	484 [4280] 245	574 [5077] 237	261
Max. Cont.	68 [18]		142 [1261] 292	264 [2333] 286	355 [3140] 282	493 [4366] 276	569 [5032] 274	655 [5799] 259	293
Max. Inter.	76 [20]		122 [1083] 324	237 [2096] 321	347 [3068] 316	453 [4009] 309	571 [5057] 305		326
	83 [22]			210 [1855] 357	338 [2987] 351	464 [4104] 345	550 [4864] 339		358
Overall Efficiency - 70 - 100% <input type="checkbox"/> 40 - 69% <input type="checkbox"/> 0 - 39% <input checked="" type="checkbox"/>									
Rotor Width									
19.7 [.777]									
mm [in]									
		Theoretical Torque - Nm [lb-in]							
		64 [565]	128 [1131]	256 [2261]	383 [3392]	511 [4522]	639 [5653]	767 [6783]	894 [7914]
Displacement tested at 54°C [129°F] with an oil viscosity of 46cSt [213 SUS]									

► Performance data is typical. Performance of production units varies slightly from one motor to another. Operating at maximum continuous pressure and maximum continuous flow simultaneously is not recommended. For additional information on product testing please refer to page 6.

DISPLACEMENT PERFORMANCE

		Pressure - bar [psi]						Max. Cont.	Max. Inter.	
350		17 [250]	35 [500]	69 [1000]	104 [1500]	138 [2000]	173 [2500]	207 [3000]	241 [3500]	
348 cm ³ [21.2 in ³] / rev								Intermittent Ratings - 10% of Operation		
Flow - lpm [gpm]	2 [0.5]	64 [566] 4	134 [1183] 4	272 [2404] 3	399 [3532] 2					6
	4 [1]	64 [570] 10	134 [1189] 9	296 [2619] 8	437 [3869] 8					11
	8 [2]	69 [607] 21	145 [1285] 20	312 [2764] 19	462 [4092] 18	600 [5308] 18	742 [6571] 17	855 [7569] 14		22
	15 [4]	71 [627] 42	151 [1340] 41	313 [2767] 40	471 [4169] 39	630 [5577] 37	772 [6834] 35	889 [7869] 34	993 [8785] 28	44
	23 [6]	62 [549] 64	149 [1618] 63	315 [2788] 62	474 [4191] 60	630 [5577] 57	768 [6796] 54	925 [8182] 51	1032 [9137] 45	66
	30 [8]	53 [472] 86	139 [1233] 85	307 [2713] 84	459 [4058] 82	626 [5537] 79	768 [6793] 75	928 [8210] 69	1051 [9300] 65	88
	38 [10]		113 [1004] 108	298 [2639] 108	431 [3814] 108	601 [5317] 102	745 [6593] 100	910 [8056] 93	1062 [9399] 87	109
	45 [12]		98 [869] 130	265 [2346] 129	445 [3936] 128	581 [5144] 125	740 [6552] 117	891 [7889] 109	1044 [9237] 104	131
	53 [14]		86 [758] 152	252 [2226] 151	422 [3738] 150	570 [5044] 147	723 [6398] 139	881 [7794] 133	1031 [9126] 120	153
	61 [16]		63 [560] 173	235 [2079] 173	409 [3619] 172	549 [4859] 170	720 [6375] 163	850 [7522] 155	1012 [8952] 147	175
	68 [18]			220 [1948] 195	394 [3490] 194	571 [5054] 190	693 [6134] 187	839 [7428] 175	986 [8727] 164	197
	76 [20]			208 [1843] 217	375 [3320] 216	513 [4544] 214	683 [6044] 213	835 [7385] 195	975 [8632] 188	218
	83 [22]			179 [1583] 239	352 [3112] 239	554 [4906] 238	685 [6064] 233	813 [7198] 221	958 [8482] 215	240
	91 [24]			172 [1526] 261	360 [3186] 261	534 [4724] 260	666 [5890] 256			262
	95 [25]				369 [3264] 271	529 [4682] 270	647 [5730] 265			273
Rotor Width		Overall Efficiency - 70 - 100% <input type="checkbox"/> 40 - 69% <input type="checkbox"/> 0 - 39% <input type="checkbox"/>								
39.4 [1.553] mm [in]		Theoretical Torque - Nm [lb-in]								
		95 [844]	191 [1688]	381 [3376]	572 [5064]	763 [6752]	954 [8439]	1144 [10127]	1335 [11815]	
		Displacement tested at 54°C [129°F] with an oil viscosity of 46cSt [213 SUS]								

		Pressure - bar [psi]						Max. Cont.	Max. Inter.	
375		17 [250]	35 [500]	69 [1000]	104 [1500]	138 [2000]	173 [2500]	207 [3000]	241 [3500]	
375 cm ³ [22.8 in ³] / rev								Intermittent Ratings - 10% of Operation		
Flow - lpm [gpm]	2 [0.5]	76 [674] 3								6
	4 [1]	84 [745] 8	162 [1432] 7	329 [2911] 6	490 [4337] 6	639 [5652] 5	763 [6756] 3			11
	8 [2]	82 [724] 18	171 [1510] 17	361 [3196] 16	537 [4754] 16	689 [6095] 14	836 [7399] 12	955 [8449] 9		21
	15 [4]	77 [680] 39	163 [1439] 37	358 [3164] 37	537 [4756] 36	695 [6151] 32	857 [7587] 29	989 [8750] 25	1121 [9923] 20	41
	23 [6]	67 [595] 60	158 [1398] 59	354 [3130] 56	527 [4661] 56	695 [6155] 52	864 [7642] 47	1011 [8951] 40	1168 [10334] 36	61
	30 [8]	57 [508] 80	149 [1321] 80	340 [3010] 78	510 [4512] 77	695 [6154] 71	845 [7476] 65	1009 [8930] 60	1156 [10229] 51	82
	38 [10]		134 [1187] 100	322 [2849] 99	495 [4383] 96	681 [6024] 93	836 [7399] 87	1007 [8913] 80	1157 [10235] 71	102
	45 [12]		115 [1013] 121	301 [2661] 120	480 [4249] 118	645 [5711] 113	809 [7159] 108	980 [8674] 98	1141 [10098] 92	122
	53 [14]		93 [819] 141	280 [2475] 140	477 [4218] 138	633 [5602] 134	795 [7036] 128	949 [8402] 120	1117 [9887] 105	142
	61 [16]		73 [646] 161	261 [2314] 161	429 [3797] 160	598 [5296] 155	770 [6817] 151	934 [8267] 141	1085 [9605] 130	163
	68 [18]			236 [2091] 181	434 [3843] 181	597 [5282] 177	765 [6771] 168	907 [8026] 161	1080 [9554] 150	183
	76 [20]			209 [1851] 202	384 [3396] 201	561 [4969] 198	740 [6549] 191	877 [7764] 183	1027 [9091] 168	203
	83 [22]			178 [1576] 222	374 [3309] 221	530 [4694] 218	696 [6160] 213	840 [7431] 205		223
	91 [24]			141 [1246] 242	319 [2822] 241	511 [4523] 239	662 [5860] 233			244
	Rotor Width		Overall Efficiency - 70 - 100% <input type="checkbox"/> 40 - 69% <input type="checkbox"/> 0 - 39% <input type="checkbox"/>							
31.8 [1.252] mm [in]		Theoretical Torque - Nm [lb-in]								
		103 [908]	205 [1815]	410 [3631]	615 [5446]	821 [7261]	1026 [9076]	1231 [10892]	1436 [12707]	
		Displacement tested at 54°C [129°F] with an oil viscosity of 46cSt [213 SUS]								

► Performance data is typical. Performance of production units varies slightly from one motor to another. Operating at maximum continuous pressure and maximum continuous flow simultaneously is not recommended. For additional information on product testing please refer to page 6.

DISPLACEMENT PERFORMANCE

		Pressure - bar [psi]					Max. Cont.	Peak
470		17 [250]	35 [500]	69 [1000]	104 [1500]	138 [2000]	173 [2500]	207 [3000]
465 cm ³ [28.3 in ³] / rev		Torque - Nm [lb-in], Speed rpm						
		Intermittent Ratings - 10% of Operation						
Flow - lpm [gpm]	2 [0.5]	93 [823] 2	185 [1635] 1					5
	4 [1]	97 [857] 7	203 [1794] 5	409 [3618] 5	610 [5402] 5	815 [7209] 4		9
	8 [2]	98 [865] 15	209 [1845] 14	435 [3851] 13	659 [5836] 13	855 [7563] 12	1025 [9071] 11	17
	15 [4]	94 [834] 31	200 [1774] 30	444 [3932] 28	659 [5829] 28	886 [7836] 26	1066 [9434] 23	1250 [11062] 21
	23 [6]	86 [759] 48	193 [1704] 47	438 [3880] 44	673 [5955] 44	872 [7715] 41	1073 [9499] 37	1258 [11128] 32
	30 [8]	73 [643] 64	179 [1587] 63	424 [3752] 60	663 [5863] 60	857 [7586] 57	1098 [9718] 50	1279 [11317] 43
	38 [10]	52 [464] 81	164 [1455] 80	407 [3597] 78	627 [5550] 78	851 [7533] 75	1067 [9444] 68	1276 [11288] 61
	45 [12]		141 [1248] 97	379 [3350] 94	630 [5575] 93	832 [7363] 90	1067 [9441] 83	1273 [11264] 76
	53 [14]		114 [1006] 113	350 [3094] 112	580 [5133] 111	802 [7101] 108	1013 [8964] 102	1222 [10817] 94
	61 [16]		83 [736] 130	322 [2846] 129	545 [4819] 127	796 [7040] 123	965 [8538] 119	1190 [10528] 113
	68 [18]		56 [497] 146	275 [2434] 145	526 [4657] 145	737 [6519] 142	956 [8464] 138	1166 [10317] 128
	76 [20]			235 [2078] 162	479 [4239] 161	706 [6249] 158	917 [8117] 154	1122 [9933] 143
83 [22]			202 [1790] 179	460 [4075] 178	669 [5920] 176	883 [7811] 170		
91 [24]			157 [1392] 195	385 [3410] 194	620 [5484] 190	843 [7464] 186		
Max. Cont.								170
Max. Inter.								196
Rotor Width		Overall Efficiency - 70 - 100% <input type="checkbox"/> 40 - 69% <input type="checkbox"/> 0 - 39% <input type="checkbox"/>						
39.4 [1.553] mm [in]		Theoretical Torque - Nm [lb-in]						
		127 [1127]	255 [2253]	509 [4506]	764 [6760]	1018 [9013]	1273 [11266]	1528 [13519]
		Displacement tested at 54°C [129°F] with an oil viscosity of 46cSt [213 SUS]						

		Pressure - bar [psi]					Max. Cont.	Max. Inter.
540		17 [250]	35 [500]	69 [1000]	104 [1500]	138 [2000]	173 [2500]	
536 cm ³ [32.7 in ³] / rev		Torque - Nm [lb-in], Speed rpm						
		Intermittent Ratings - 10% of Operation						
Flow - lpm [gpm]	2 [0.5]	104 [921] 2	197 [1748] 2					4
	4 [1]	126 [1111] 6	230 [2031] 5	467 [4136] 5	699 [6183] 5	939 [8310] 5	1149 [10165] 4	8
	8 [2]	134 [1189] 13	240 [2120] 13	501 [4436] 12	755 [6679] 12	977 [8646] 11	1185 [10484] 10	15
	15 [4]	120 [1058] 27	232 [2055] 27	510 [4510] 26	757 [6697] 26	988 [8740] 24	1223 [10827] 23	29
	23 [6]	97 [859] 41	224 [1984] 41	505 [4469] 40	783 [6930] 40	993 [8787] 38	1225 [10838] 34	43
	30 [8]	78 [692] 56	213 [1887] 56	484 [4285] 55	750 [6635] 54	983 [8698] 53	1251 [11075] 48	57
	38 [10]	59 [523] 70	190 [1678] 70	455 [4026] 69	728 [6445] 69	959 [8487] 67	1244 [11008] 62	71
	45 [12]		176 [1554] 84	438 [3879] 83	719 [6360] 83	945 [8360] 80	1203 [10646] 77	85
	53 [14]		139 [1233] 98	418 [3703] 97	682 [6035] 96	952 [8421] 94	1183 [10467] 91	99
	61 [16]		109 [963] 112	385 [3407] 111	668 [5908] 111	899 [7957] 110	1163 [10290] 105	114
	68 [18]		83 [736] 126	356 [3154] 126	612 [5417] 125	869 [7694] 124	1116 [9876] 123	128
	76 [20]			323 [2861] 140	603 [5333] 139	829 [7335] 138	1109 [9816] 134	142
83 [22]			297 [2629] 154	537 [4753] 153	792 [7011] 152		156	
91 [24]			215 [1905] 169	491 [4349] 168	750 [6639] 168		170	
Max. Cont.							170	
Max. Inter.							170	
Rotor Width		Overall Efficiency - 70 - 100% <input type="checkbox"/> 40 - 69% <input type="checkbox"/> 0 - 39% <input type="checkbox"/>						
45.5 [1.791] mm [in]		Theoretical Torque - Nm [lb-in]						
		147 [1302]	294 [2604]	588 [5207]	883 [7811]	1177 [10414]	1471 [13018]	
		Displacement tested at 54°C [129°F] with an oil viscosity of 46cSt [213 SUS]						

► Performance data is typical. Performance of production units varies slightly from one motor to another. Operating at maximum continuous pressure and maximum continuous flow simultaneously is not recommended. For additional information on product testing please refer to page 6.

DISPLACEMENT PERFORMANCE

		Pressure - bar [psi]				Max. Cont.	Max. Inter.	
620		17 [250]	35 [500]	69 [1000]	104 [1500]	121 [1750]	155 [2250]	
631 cm ³ [38.5 in ³] / rev								
		Torque - Nm [lb-in], Speed rpm				Intermittent Ratings - 10% of Operation		
Flow - lpm [gpm]	2 [0.5]	120 [1060] 2	228 [2021] 1				3	
	4 [1]	136 [1202] 5	264 [2332] 5	535 [4733] 5	796 [7048] 4	935 [8275] 3	6	
	8 [2]	142 [1256] 11	276 [2445] 11	571 [5055] 11	853 [7550] 10	985 [8717] 9	1256 [11117] 7	12
	15 [4]	131 [1159] 23	269 [2379] 23	581 [5141] 23	870 [7696] 22	1008 [8920] 21	1279 [11320] 17	24
	23 [6]	111 [982] 35	260 [2300] 35	575 [5087] 34	883 [7811] 34	1014 [8976] 33	1285 [11368] 29	36
	30 [8]	91 [809] 47	247 [2184] 47	555 [4914] 46	855 [7570] 45	1000 [8853] 44	1291 [11421] 40	48
	38 [10]	67 [595] 59	220 [1943] 58	526 [4655] 58	833 [7372] 57	972 [8602] 56	1268 [11225] 52	60
	45 [12]		203 [1794] 71	504 [4456] 70	815 [7208] 70	953 [8437] 69	1240 [10977] 65	72
	53 [14]		160 [1419] 83	476 [4213] 81	778 [6888] 80	930 [8233] 79	1225 [10843] 78	84
	61 [16]		124 [1095] 95	439 [3885] 94	753 [6666] 93	895 [7917] 92	1187 [10509] 90	96
	68 [18]		91 [801] 107	407 [3599] 107	703 [6223] 106	852 [7537] 105	1147 [10147] 104	108
	76 [20]			358 [3172] 119	675 [5974] 118	815 [7215] 117	1100 [9736] 115	120
	83 [22]			328 [2901] 131	614 [5431] 131	759 [6715] 130		132
	91 [24]			247 [2185] 143	556 [4922] 142	706 [6249] 141		144
Max. Cont.								
Max. Inter.								
Rotor Width		Overall Efficiency - 70 - 100% <input type="checkbox"/> 40 - 69% <input type="checkbox"/> 0 - 39% <input checked="" type="checkbox"/>						
54.0 [2.125] mm [in]		Theoretical Torque - Nm [lb-in]						
		173 [1532]	346 [3064]	692 [6127]	1039 [9191]	1212 [10729]	1559 [13794]	
Displacement tested at 54°C [129°F] with an oil viscosity of 46cSt [213 SUS]								

		Pressure - bar [psi]				Max. Cont.	Peak
750		17 [250]	35 [500]	69 [1000]	104 [1500]	138 [2000]	
748 cm ³ [45.6 in ³] / rev							
		Torque - Nm [lb-in], Speed rpm				Intermittent Ratings - 10% of Operation	
Flow - lpm [gpm]	2 [0.5]	147 [1299] 2	281 [2487] 1				3
	4 [1]	156 [1379] 4	322 [2852] 4	652 [5768] 4	967 [8554] 3	1308 [11571] 3	6
	8 [2]	158 [1403] 9	339 [3003] 9	693 [6134] 9	1027 [9088] 8	1360 [12033] 7	11
	15 [4]	153 [1350] 19	331 [2933] 19	705 [6241] 19	1064 [9419] 18	1416 [12534] 16	21
	23 [6]	135 [1194] 29	321 [2840] 29	697 [6166] 28	1059 [9373] 28	1408 [12462] 26	31
	30 [8]	114 [1008] 40	304 [2690] 40	678 [6002] 39	1039 [9197] 38	1421 [12573] 34	41
	38 [10]	82 [722] 50	271 [2395] 49	648 [5733] 49	1015 [8980] 48	1371 [12130] 47	51
	45 [12]	54 [477] 60	249 [2207] 60	616 [5452] 59	983 [8699] 59	1345 [11902] 56	61
	53 [14]		197 [1739] 70	577 [5104] 69	946 [8372] 68	1311 [11600] 67	71
	61 [16]		150 [1325] 80	533 [4718] 79	905 [8008] 78	1271 [11249] 76	82
	68 [18]		105 [927] 90	494 [4374] 90	860 [7614] 89	1225 [10843] 88	92
	76 [20]		62 [552] 100	423 [3741] 100	805 [7123] 99	1173 [10385] 98	102
	83 [22]			385 [3404] 110	747 [6608] 110		112
	91 [24]			302 [2669] 121	670 [5932] 120		122
Max. Cont.							
Max. Inter.							
Rotor Width		Overall Efficiency - 70 - 100% <input type="checkbox"/> 40 - 69% <input type="checkbox"/> 0 - 39% <input checked="" type="checkbox"/>					
63.5 [2.501] mm [in]		Theoretical Torque - Nm [lb-in]					
		205 [1815]	410 [3631]	821 [7261]	1231 [10892]	1641 [14522]	
Displacement tested at 54°C [129°F] with an oil viscosity of 46cSt [213 SUS]							

► Performance data is typical. Performance of production units varies slightly from one motor to another. Operating at maximum continuous pressure and maximum continuous flow simultaneously is not recommended. For additional information on product testing please refer to page 6.

HOUSINGS

► Dimensions shown are without paint. Paint thickness can be up to 0.13 [.005].

4-HOLE, MAGNETO MOUNT, ALIGNED PORTS

A31 7/8-14 UNF **A38** G 1/2

STANDARD

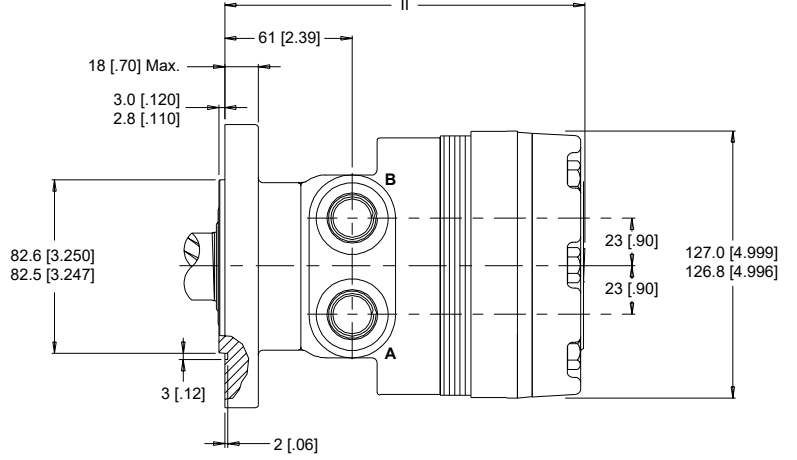
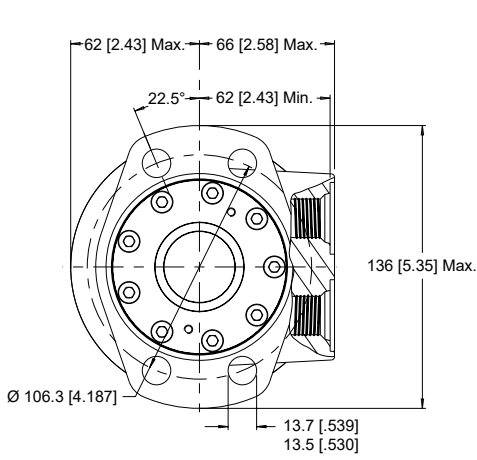

OPTIONAL VALVE CAVITY

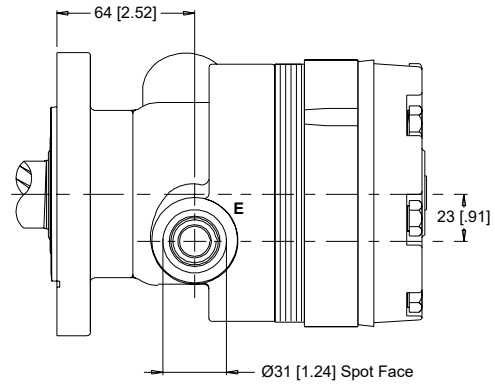
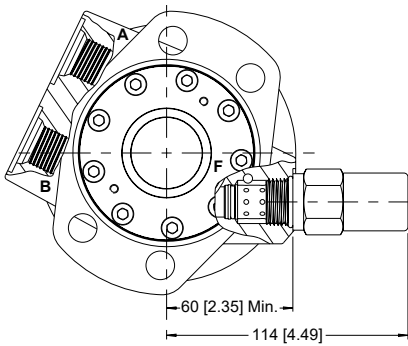

E: 10 Series/2-Way Valve Cavity 7/8-14 UNF F: Valve Cartridge Installed

6-HOLE, SAE A MOUNT, ALIGNED PORTS

A51 7/8-14 UNF **A58** G 1/2

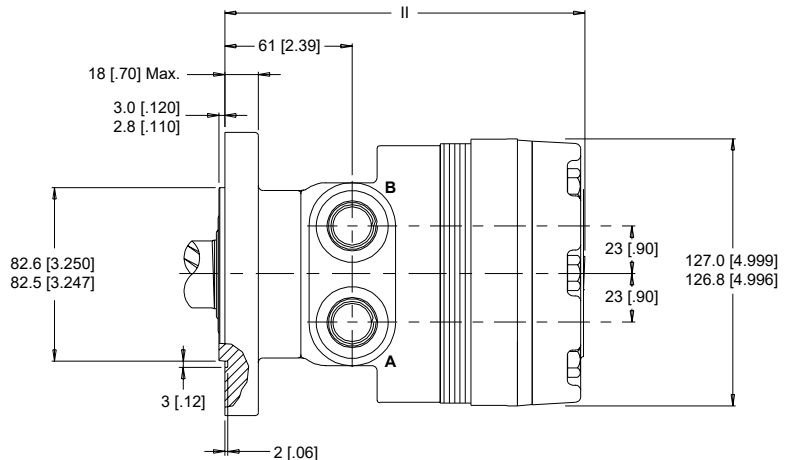
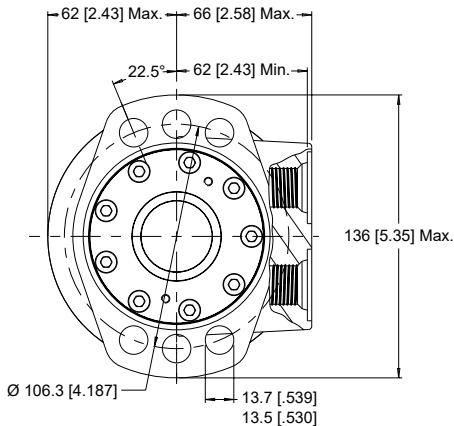

► Dimension II is charted on page 25.

RE (505/506 Series)
Medium Duty Hydraulic Motor

HOUSINGS

► Dimensions shown are without paint. Paint thickness can be up to 0.13 [0.005].

4-HOLE, WHEEL MOUNT, ALIGNED PORTS

W31 7/8-14 UNF **W38** G 1/2

STANDARD

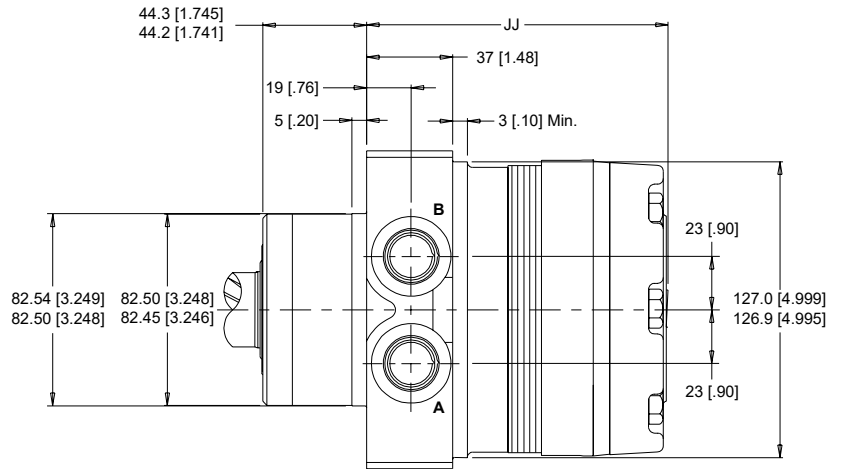
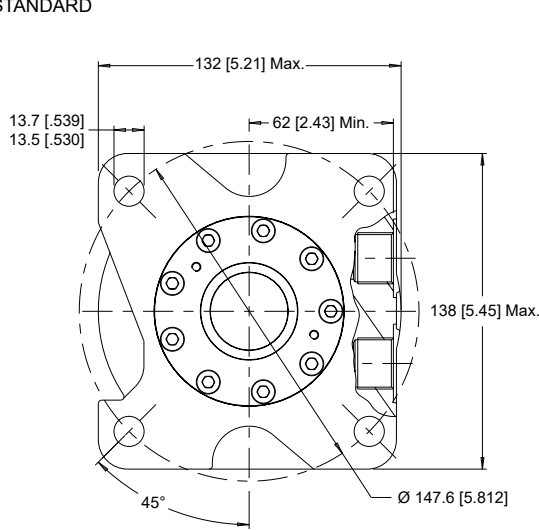

OPTIONAL VALVE CAVITY

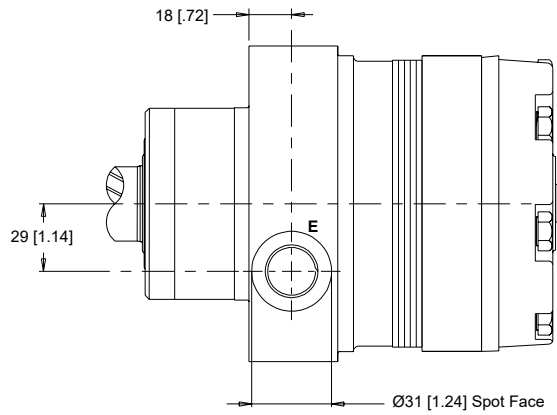
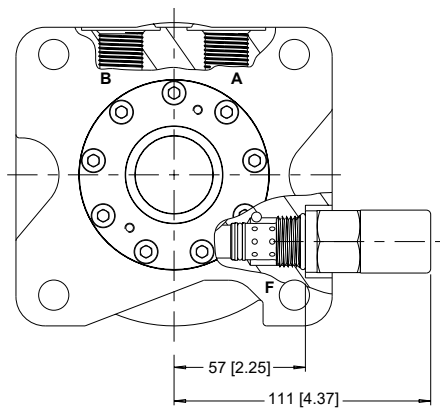

E: 10 Series/2-Way Valve Cavity 7/8-14 UNF **F:** Valve Cartridge Installed

► Dimension JJ is charted on page 25.

TECHNICAL INFORMATION

ALLOWABLE SHAFT LOAD / BEARING CURVE

The bearing curve represents allowable bearing loads based on ISO 281 bearing capacity for an L_{10} life of 2,000 hours at 100 rpm. Radial loads for speeds other than 100 rpm may be calculated using the multiplication factor table on page 7.

MAGNETO & SAE A MOUNTS

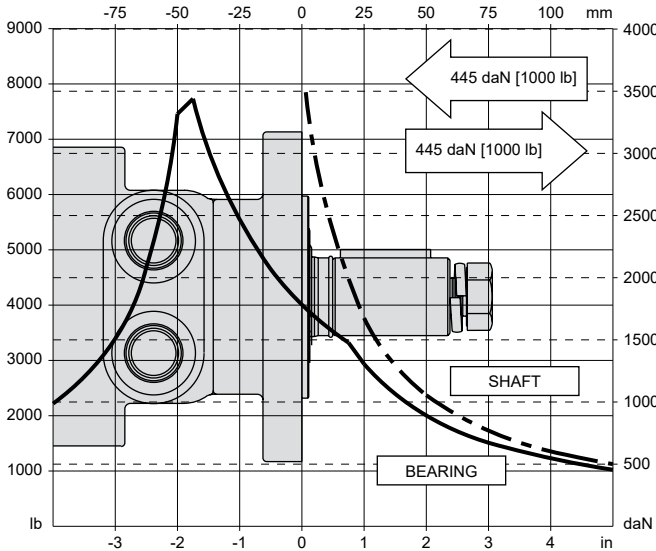

WHEEL MOUNTS

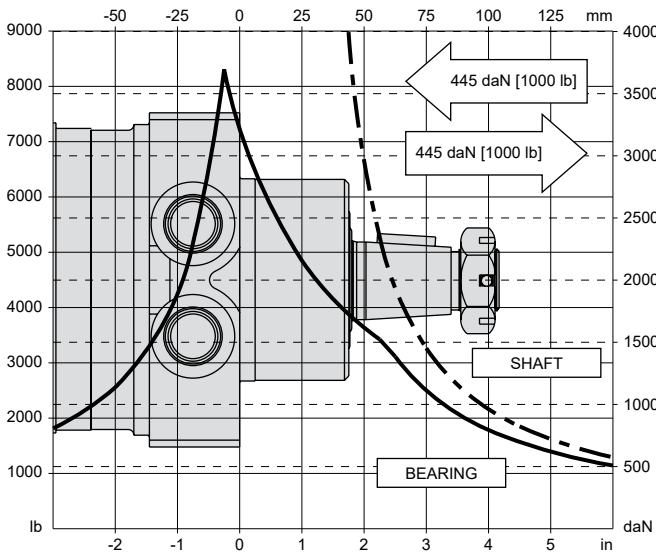

LENGTH & WEIGHT CHART

Dimensions II & JJ are the overall motor lengths from the rear of the motor to the mounting flange surface and are referenced on detailed housing drawings listed on pages 23 & 24.

II	Length	Weight
#	mm [in]	kg [lb]
120	162 [6.37]	10.6 [23.4]
160	162 [6.37]	10.6 [23.4]
200	165 [6.51]	11.0 [24.2]
230	168 [6.61]	11.1 [24.4]
260	170 [6.70]	11.3 [25.0]
300	174 [6.83]	11.7 [25.8]
350	187 [7.38]	12.8 [28.2]
375	180 [7.08]	12.2 [27.0]
470	187 [7.38]	12.8 [28.2]
540	194 [7.62]	13.3 [29.4]
620	202 [7.95]	14.1 [30.9]
750	212 [8.33]	14.8 [32.5]

JJ	Length	Weight
#	mm [in]	kg [lb]
120	120 [4.72]	11.7 [25.8]
160	120 [4.72]	11.7 [25.8]
200	123 [4.86]	12.1 [26.6]
230	126 [4.95]	12.2 [26.8]
260	128 [5.05]	12.4 [27.4]
300	132 [5.18]	12.8 [28.2]
350	146 [5.73]	13.9 [30.6]
375	138 [5.43]	13.3 [29.4]
470	146 [5.73]	13.9 [30.6]
540	152 [5.97]	14.4 [31.8]
620	161 [6.35]	15.1 [33.4]
750	170 [6.68]	15.8 [34.9]

► All RE series motor weights can vary ± 0.5 kg [1 lb] depending on model configurations such as housing, shaft, endcover, options etc.

SHAFTS

02 1" 6B Spline

6B Spline
SAE J499 Standard

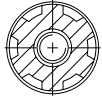

5/16-18 UNC, Min. Depth 18 [.70]

03 1" 6B Spline Extended

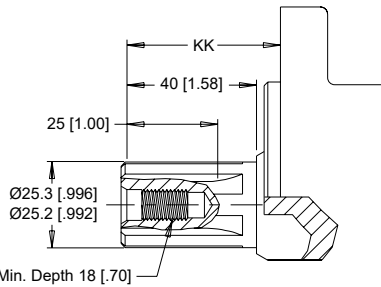

Max. Torque: 678 Nm [6000 lb-in]

10 1" Straight

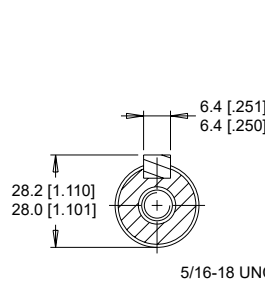

Max. Torque: 655 Nm [5800 lb-in]

15 1" Straight Extended

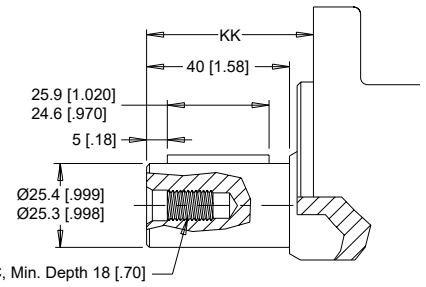

07 1-1/4" Straight Extended

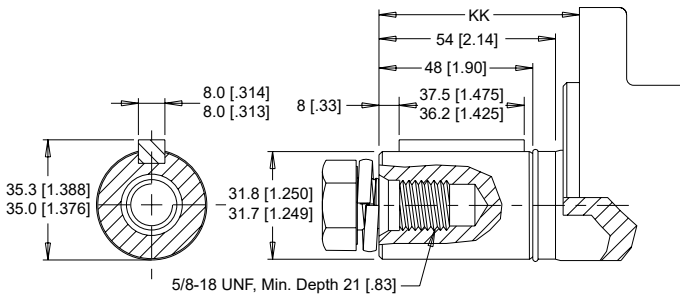

Max. Torque: 1200 Nm [10600 lb-in]

20 1-1/4" Straight

12 25mm Straight

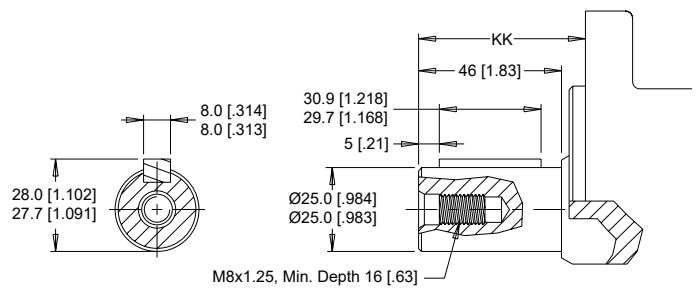

Max. Torque: 678 Nm [6000 lb-in]

08 32mm Straight Extended

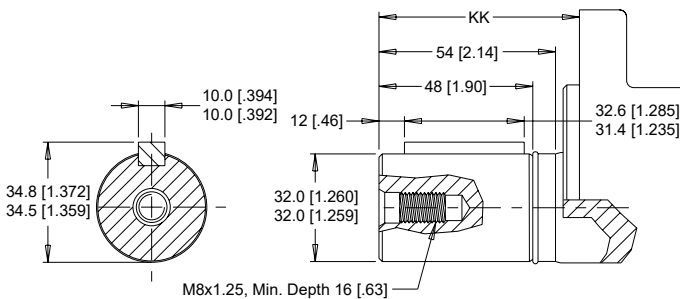

Max. Torque: 1200 Nm [10600 lb-in]

21 32mm Straight

22 1-1/4" Tapered

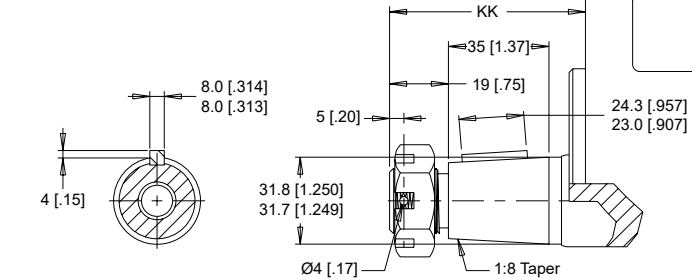

Max. Torque: 1200 Nm [10600 lb-in]

25 1-1/4" Tapered Extended

► A slotted hex nut is standard on this shaft.

09 14 Tooth Spline Extended

14 Tooth Spline 12/24 Pitch
Standard ANSI B92.1-1996 Spline

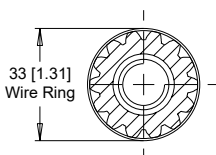

33 [1.31]
Wire Ring

5/8-18 UNF, Min. Depth 21 [.83]

23 14 Tooth Spline

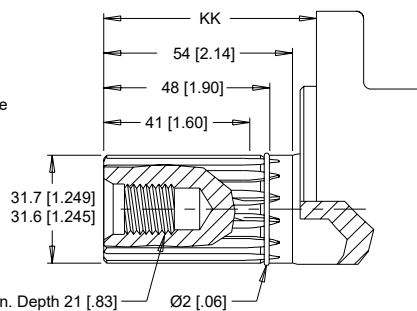

Max. Torque: 1200 Nm [10600 lb-in]

MOUNTING / SHAFT LENGTH CHART

Dimension KK is the overall distance from the motor mounting surface to the end of the shaft and is referenced on detailed shaft drawings above.

KK	Magneto & A Mounts	Wheel Mounts
#	mm [in]	mm [in]
02	50 [1.97]	91 [3.60]
03	76 [3.01]	118 [4.64]
07	88 [3.45]	129 [5.09]
08	88 [3.45]	129 [5.09]
09	88 [3.45]	129 [5.09]
10	50 [1.97]	91 [3.60]
12	56 [2.21]	98 [3.84]
15	76 [3.01]	118 [4.64]
20	61 [2.41]	103 [4.05]
21	61 [2.41]	103 [4.05]
22	66 [2.58]	107 [4.22]
23	61 [2.41]	103 [4.05]
25	92 [3.62]	134 [5.26]

► Shaft lengths vary ± 0.8 mm [.030 in.]

ORDERING INFORMATION



1. CHOOSE SERIES DESIGNATION

505 Standard Rotation

506 Reverse Rotation

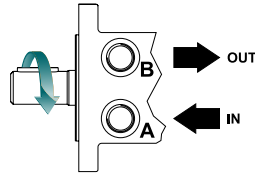
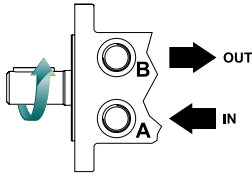

► The 505 & 506 series are bi-directional. For applications requiring the motor to rotate in only one direction, shaft seal life may be prolonged by pressurizing the A port of the motor.

2. SELECT A DISPLACEMENT OPTION

120	121 cm ³ /rev [7.4 in ³ /rev]	350	348 cm ³ /rev [21.2 in ³ /rev]
160	162 cm ³ /rev [9.9 in ³ /rev]	375	375 cm ³ /rev [22.8 in ³ /rev]
200	204 cm ³ /rev [12.4 in ³ /rev]	470	465 cm ³ /rev [28.3 in ³ /rev]
230	232 cm ³ /rev [14.2 in ³ /rev]	540	536 cm ³ /rev [32.7 in ³ /rev]
260	261 cm ³ /rev [15.9 in ³ /rev]	620	631 cm ³ /rev [38.5 in ³ /rev]
300	300 cm ³ /rev [18.3 in ³ /rev]	750	748 cm ³ /rev [45.6 in ³ /rev]

3. SELECT A MOUNT & PORT OPTION

A31	4-Hole, Magneto Mount, Aligned Ports, 7/8-14 UNF
A38	4-Hole, Magneto Mount, Aligned Ports, G 1/2
A51	6-Hole, SAE A Mount, Aligned Ports, 7/8-14 UNF
A58	6-Hole, SAE A Mount, Aligned Ports, G 1/2
W31	4-Hole, Wheel Mount, Aligned Ports, 7/8-14 UNF
W38	4-Hole, Wheel Mount, Aligned Ports, G 1/2

► Speed sensor option is not available with wheel mounts

4. SELECT A SHAFT OPTION

02	1" 6B Spline	15	1" Straight Extended
03	1" 6B Spline Extended	20	1-1/4" Straight
07	1-1/4" Straight Extended	21	32mm Straight
08	32mm Straight Extended	22	1-1/4" Tapered
09	14 Tooth Spline Extended	23	14 Tooth Spline
10	1" Straight	25	1-1/4" Tapered Extended
12	25mm Straight		

► Extended shafts are designed for use with one of the speed sensor options listed in STEP 7.

5. SELECT A PAINT OPTION

A	Black
B	Black, Unpainted Mounting Surface
Z	No Paint

6. SELECT A VALVE CAVITY / CARTRIDGE OPTION

A	None	E	104 bar [1500 psi] Relief
B	Valve Cavity Only	F	121 bar [1750 psi] Relief
C	69 bar [1000 psi] Relief	G	138 bar [2000 psi] Relief
D	86 bar [1250 psi] Relief		

► Valve cavity is not available on the A51 & A58 housings.

7. SELECT AN ADD-ON OPTION

A	Standard
B	Lock Nut
C	Solid Hex Nut
W	Speed Sensor, Dual, 4-Pin Male Weatherpack Connector
X	Speed Sensor, Dual, 4-Pin M12 Male Connector
Y	Speed Sensor, Single, 3-Pin Male Weatherpack Connector
Z	Speed Sensor, Single, 4-Pin M12 Male Connector

8. SELECT A MISCELLANEOUS OPTION

AA	None
AC	Freeturning Rotor
AE	Hydraulic Declutch with Freeturning Rotor

RE (530/531 Series)
Medium Duty Hydraulic Motor

HOUSINGS

► Dimensions shown are without paint. Paint thickness can be up to 0.13 [.005].

6-HOLE, SAE A MOUNT, ALIGNED PORTS

A51 7/8-14 UNF **A58** G 1/2

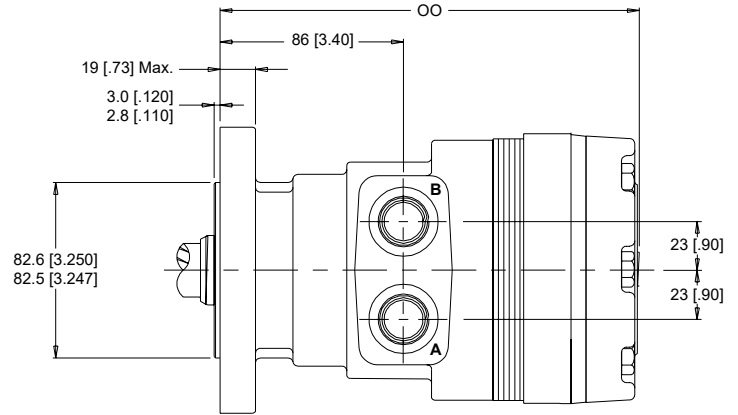
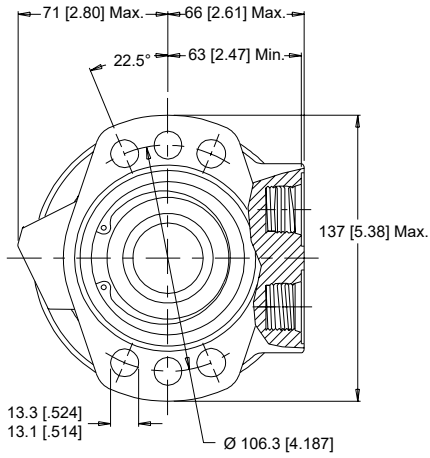

4-HOLE, WHEEL MOUNT, ALIGNED PORTS

T31 7/8-14 UNF **T38** G 1/2 **W31** 7/8-14 UNF **W38** G 1/2

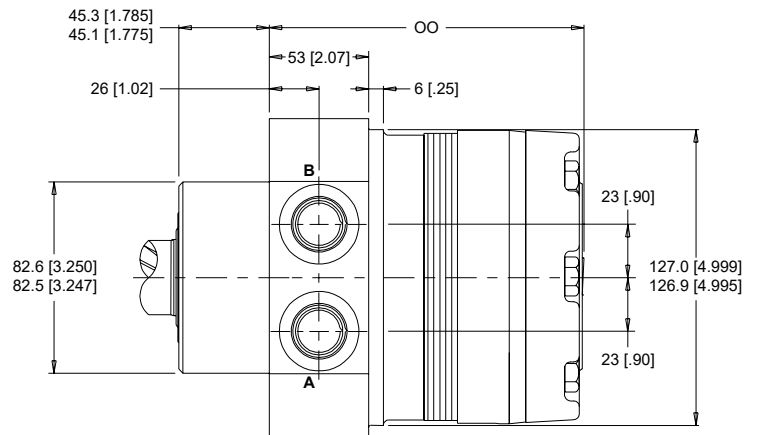
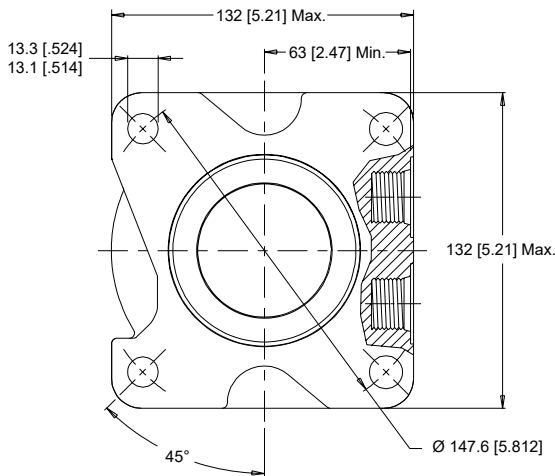

► Dimension OO is charted on page 29.

TECHNICAL INFORMATION

ALLOWABLE SHAFT LOAD / BEARING CURVE

The bearing curve represents allowable bearing loads based on ISO 281 bearing capacity for an L_{10} life of 2,000 hours at 100 rpm. Radial loads for speeds other than 100 rpm may be calculated using the multiplication factor table on page 7.

SAE A MOUNTS

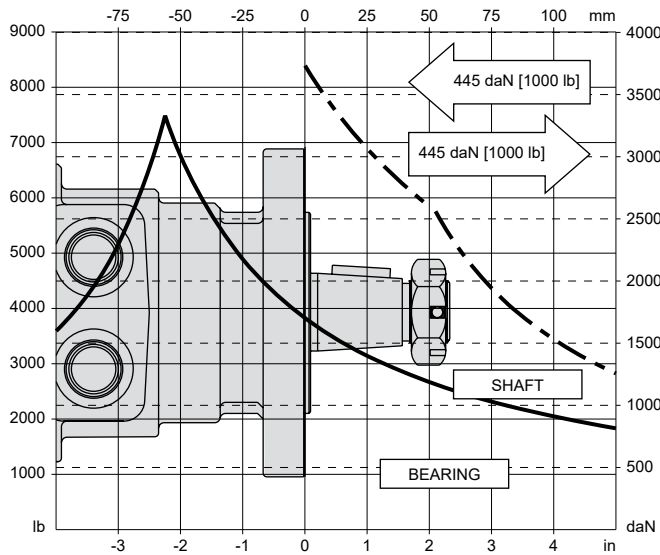

T31 & T38 WHEEL MOUNTS

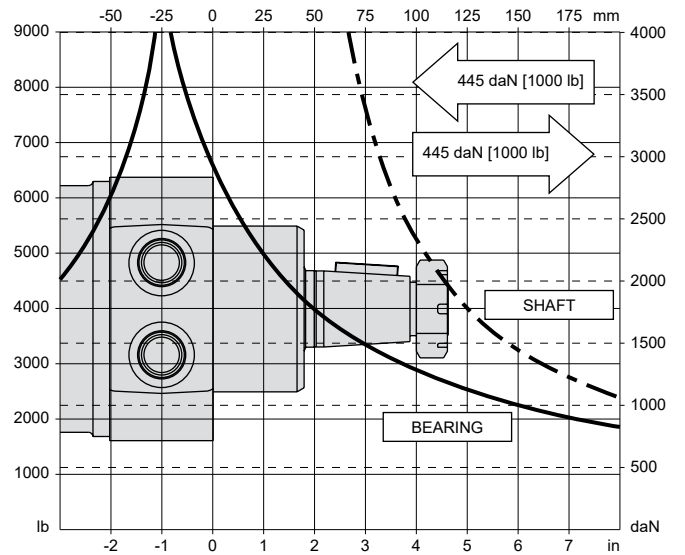

W31 & W38 WHEEL MOUNTS

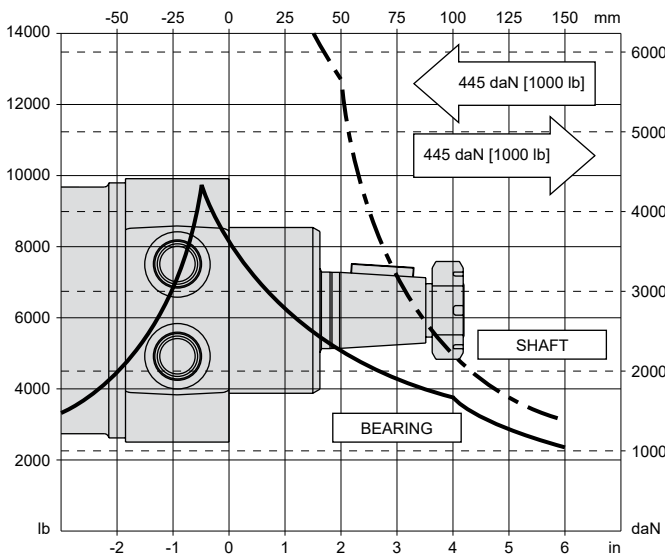

LENGTH & WEIGHT CHART

Dimension OO is the overall motor length from the rear of the motor to the mounting flange surface and are referenced on detailed housing drawings listed on page 28.

OO #	SAE A Mounts mm [in]	Wheel Mounts mm [in]	Weight kg [lb]
120	187 [7.37]	156 [6.15]	13.3 [29.4]
160	187 [7.37]	156 [6.15]	13.3 [29.4]
200	191 [7.51]	159 [6.29]	13.7 [30.2]
230	193 [7.61]	162 [6.38]	13.8 [30.4]
260	196 [7.70]	165 [6.48]	14.1 [31.0]
300	199 [7.83]	168 [6.61]	14.4 [31.8]
350	213 [8.38]	182 [7.16]	15.5 [34.2]
375	205 [8.08]	174 [6.86]	15.0 [33.0]
470	213 [8.38]	182 [7.16]	15.5 [34.2]
540	219 [8.62]	188 [7.40]	16.1 [35.4]
620	227 [8.95]	196 [7.77]	16.8 [36.9]
750	237 [9.33]	206 [8.11]	17.5 [38.5]

► All RE series motor weights can vary ± 0.5 kg [1 lb] depending on model configurations such as housing, shaft, endcover, options etc.

SHAFTS

27 35mm Straight

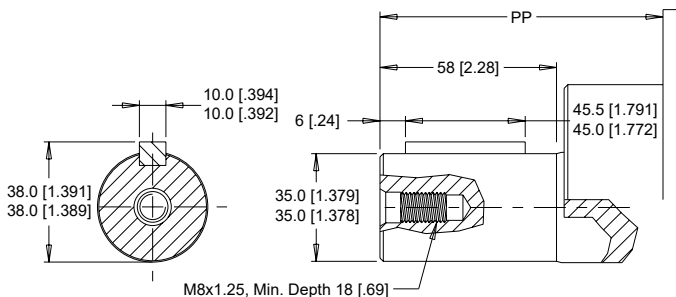

Max. Torque: 1200 Nm [10600 lb-in]

30 1-1/2" Straight

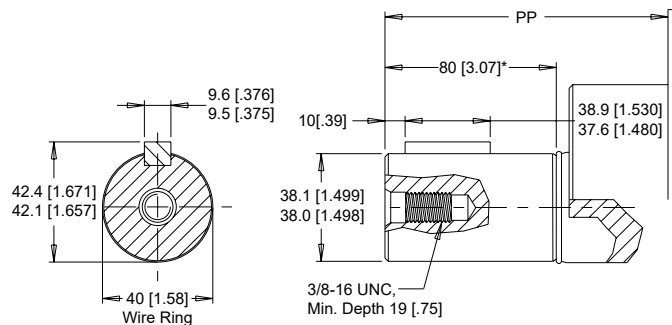

Max. Torque: 1200 Nm [10600 lb-in]

* Dimension is 68 [2.67] for wheel mounts

28 35mm Tapered

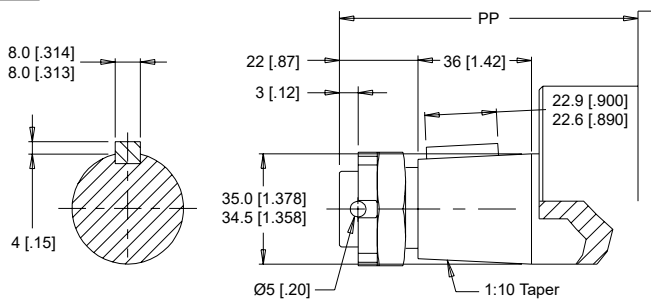

▶ A slotted hex nut is standard on this shaft.

Max. Torque: 1200 Nm [10600 lb-in]

31 1-1/2" Tapered

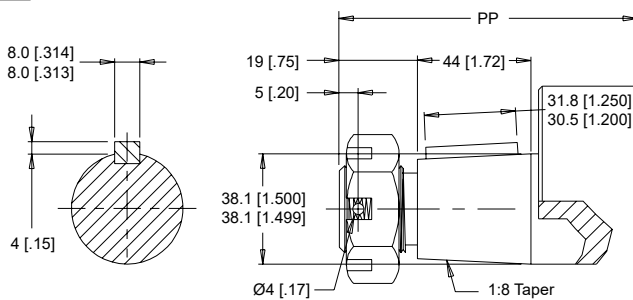

▶ A slotted hex nut is standard on this shaft.

Max. Torque: 1200 Nm [10600 lb-in]

M4 1-3/8" Tapered

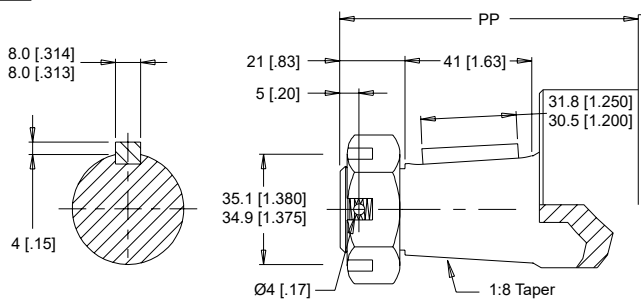

▶ A slotted hex nut is standard on this shaft.

Max. Torque: 1200 Nm [10600 lb-in]

MOUNTING / SHAFT LENGTH CHART

Dimension PP is the overall distance from the motor mounting surface to the end of the shaft and is referenced on detailed shaft drawings above.

▶ Shaft lengths vary ± 0.8 mm [0.030 in.]

PP #	SAE A Mounts	Wheel Mounts
#	mm [in]	mm [in]
27	N/A	104 [3.97]
28	N/A	105 [4.14]
30	87 [3.42]	118 [4.63]
31	84 [3.32]	115 [4.53]
M4	83 [3.28]	114 [4.49]

ORDERING INFORMATION

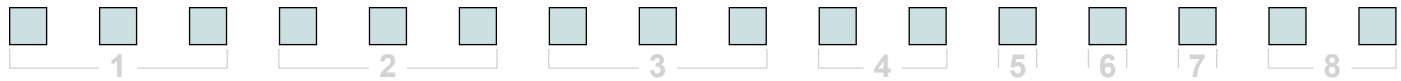

1. CHOOSE SERIES DESIGNATION

- 530** Standard Rotation
- 531** Reverse Rotation

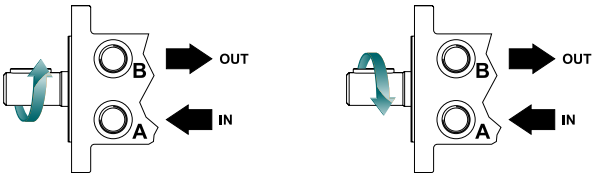

► The 530 & 531 series are bi-directional. For applications requiring the motor to rotate in only one direction, shaft seal life may be prolonged by pressurizing the A port of the motor.

2. SELECT A DISPLACEMENT OPTION

120	121 cm ³ /rev [7.4 in ³ /rev]	350	348 cm ³ /rev [21.2 in ³ /rev]
160	162 cm ³ /rev [9.9 in ³ /rev]	375	375 cm ³ /rev [22.8 in ³ /rev]
200	204 cm ³ /rev [12.4 in ³ /rev]	470	465 cm ³ /rev [28.3 in ³ /rev]
230	232 cm ³ /rev [14.2 in ³ /rev]	540	536 cm ³ /rev [32.7 in ³ /rev]
260	261 cm ³ /rev [15.9 in ³ /rev]	620	631 cm ³ /rev [38.5 in ³ /rev]
300	300 cm ³ /rev [18.3 in ³ /rev]	750	748 cm ³ /rev [45.6 in ³ /rev]

3. SELECT A MOUNT & PORT OPTION

A51	6-Hole, SAE A Mount, Aligned Ports, 7/8-14 UNF
A58	6-Hole, SAE A Mount, Aligned Ports, G 1/2
T31	4-Hole, Wheel Mount, Aligned Ports, 7/8/14 UNF
T38	4-Hole, Wheel Mount, Aligned Ports, G 1/2
W31	4-Hole, Wheel Mount, Aligned Ports, 7/8/14 UNF
W38	4-Hole, Wheel Mount, Aligned Ports, G 1/2

4. SELECT A SHAFT OPTION

- 27** 35mm Straight
- 28** 35mm Tapered
- 30** 1-1/2" Straight
- 31** 1-1/2" Tapered
- M4** 1-3/8" Tapered

► The 27 & 28 shafts are not available with SAE A mounts. The M4 shaft is only available with the "T" mount wheel motors.

5. SELECT A PAINT OPTION

- A** Black
- B** Black, Unpainted Mounting Surface
- Z** No Paint

6. SELECT A VALVE CAVITY / CARTRIDGE OPTION

- A** None

7. SELECT AN ADD-ON OPTION

- A** Standard
- B** Lock Nut
- C** Solid Hex Nut

8. SELECT A MISCELLANEOUS OPTION

- AA** None
- AC** Freeturning Rotor
- AE** Hydraulic Declutch with Freeturning Rotor

HOUSINGS

► Dimensions shown are without paint. Paint thickness can be up to 0.13 [.005].

4-HOLE, WHEEL MOUNT, ALIGNED PORTS

T31 7/8-14 UNF

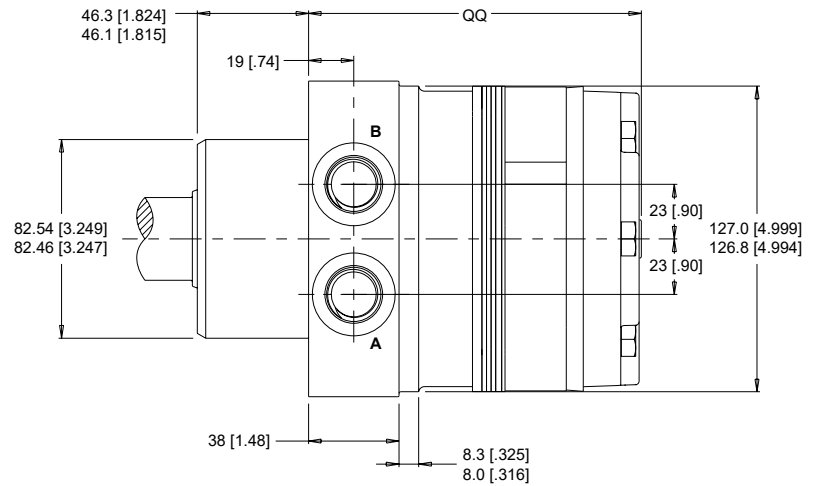
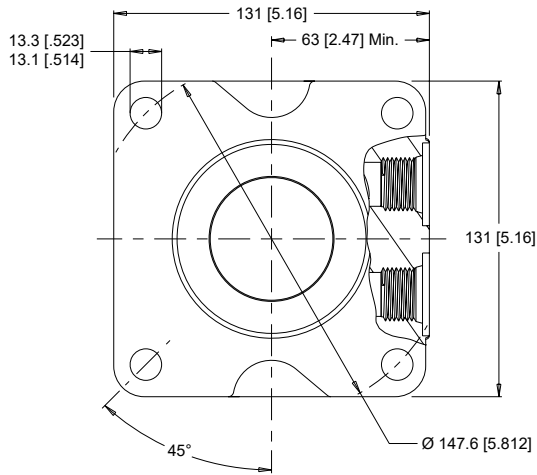

TECHNICAL INFORMATION

ALLOWABLE SHAFT LOAD / BEARING CURVE

The bearing curve represents allowable bearing loads based on ISO 281 bearing capacity for an L_{10} life of 2,000 hours at 100 rpm. Radial loads for speeds other than 100 rpm may be calculated using the multiplication factor table on page 7.

WHEEL MOUNT

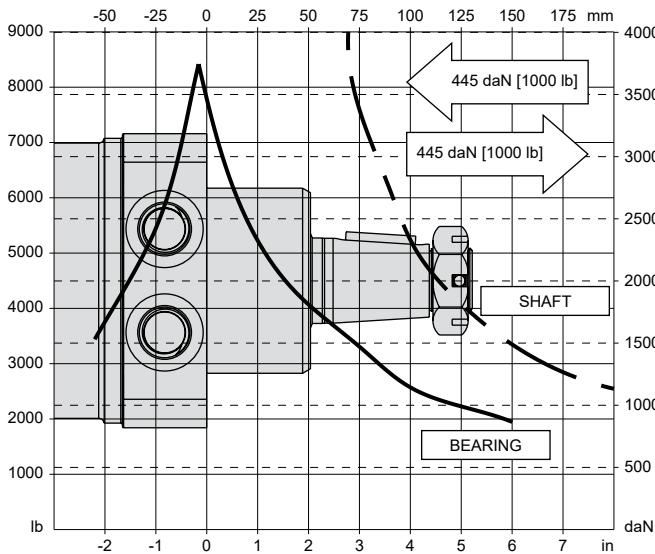

LENGTH & WEIGHT CHART

Dimension QQ is the overall motor length from the rear of the motor to the mounting flange surface and are referenced on detailed housing drawings listed above.

QQ #	Length mm [in]	Weight kg [lb]
200	129 [5.08]	13.7 [30.1]
230	132 [5.18]	13.8 [30.4]
300	137 [5.40]	14.4 [31.7]
375	144 [5.65]	15.0 [33.0]

► All RE series motor weights can vary ± 0.5 kg [1 lb] depending on model configurations such as housing, shaft, endcover, options etc.

SHAFTS

22 1-1/4" Tapered

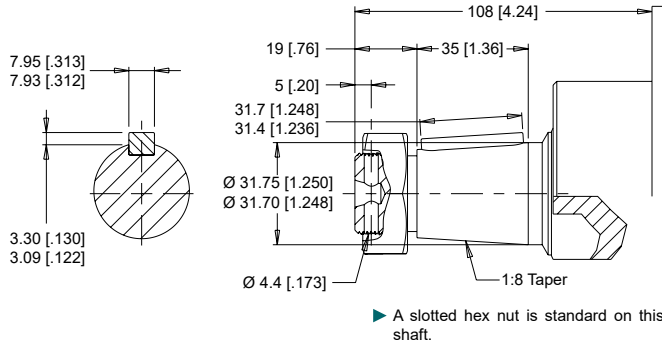

Max. Torque: 1200 Nm [10600 lb-in]

31 1-1/2" Tapered

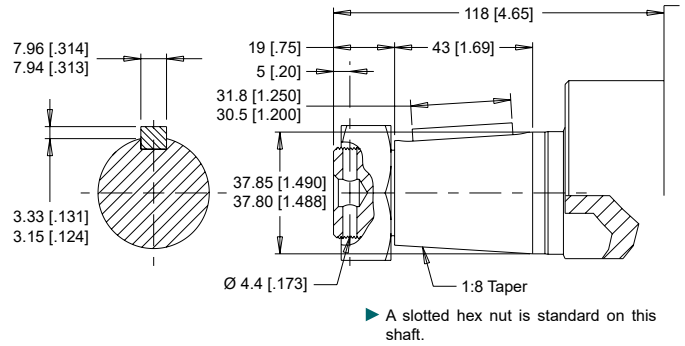

Max. Torque: 1200 Nm [10600 lb-in]

ORDERING INFORMATION

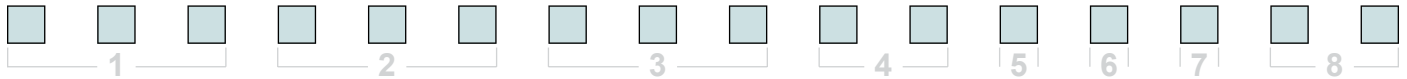

1. CHOOSE SERIES DESIGNATION

- 535** Standard Rotation
- 536** Reverse Rotation

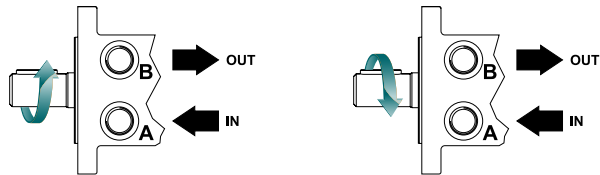

► The 535 & 536 series are bi-directional. For applications requiring the motor to rotate in only one direction, shaft seal life may be prolonged by pressurizing the A port of the motor.

2. SELECT A DISPLACEMENT OPTION

- 200** 204 cm³/rev [12.4 in³/rev]
- 230** 232 cm³/rev [14.2 in³/rev]
- 300** 300 cm³/rev [18.3 in³/rev]
- 375** 375 cm³/rev [22.8 in³/rev]

3. SELECT A MOUNT & PORT OPTION

- T31** 4-Hole, Wheel Mount, Aligned Ports, 7/8/14 UNF

4. SELECT A SHAFT OPTION

- 22** 1-1/4" Tapered
- 31** 1-1/2" Tapered

5. SELECT A PAINT OPTION

- A** Black
- B** Black, Unpainted Mounting Surface
- Z** No Paint

6. SELECT A VALVE CAVITY / CARTRIDGE OPTION

- A** None

7. SELECT AN ADD-ON OPTION

- A** Standard

8. SELECT A MISCELLANEOUS OPTION

- AA** None