

Product data sheet

Article number:

Castors 150 mm, total brake, PA6 wheels

Swivel bracket with total brake. Pressed galvanised sheet metal shackle with double rows of balls in the slewing ring. Fixing plate. Screwed wheel axle. Wheels in white nylon/ PA6 with wire guard. Double ball bearings.



The image may differ from the product.

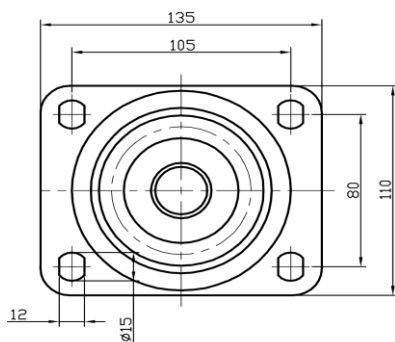

TECHNICAL DATA

| | |
|----------------------------------|----------------------|
| Wheel diameter (mm) | 150 |
| Track width (mm) | 45 |
| Offset (mm) | 55 |
| Plate size (mm) | 140x110 |
| CC distance (mm) | 105x80 |
| Construction | 194 |
| Dynamic weight capacity (kg) | 750 |
| Hardness of the track (shore) | 83° Shore D |
| Temperature range C° | -20°C to +70°C |
| Net weight kg | 3,17 |
| Material certification | RoHS (EU) - Approved |
| Dynamic weight resistance 4 km/h | 750 |
| Hole diameter plate (mm) | 13 |
| Wheel attachment | Plate |
| Wheel variant (brake) | Total brake |
| Wheel | Double ball bearings |
| Article number EAN | |
| HS code | 8716909098 |

Numerical values in the technical specification may be nominal/rounded to the nearest standard dimension. For exact values, please refer to the drawing.