



Operation Manual

PRODUCT NAME

Solid State Auto Switch

MODEL / Series / Product Number

D-M9#A#

SMC Corporation

Contents

Safety Instructions	2
Model Indication and How to Order	8
Summary of Product parts	10
Definition and terminology	10
Mounting and Installation	11
Installation	11
Circuit diagram	12
Troubleshooting	13
Specification	17
Specifications	17
Dimensions	18



Safety Instructions

These safety instructions are intended to prevent hazardous situations and/or equipment damage. These instructions indicate the level of potential hazard with the labels of "Caution", "Warning" or "Danger". They are all important notes for safety and must be followed in addition to International Standards (ISO/IEC)*1), and other safety regulations.

*1) ISO 4414: Pneumatic fluid power -- General rules relating to systems.

ISO 4413: Hydraulic fluid power -- General rules relating to systems.

IEC 60204-1: Safety of machinery -- Electrical equipment of machines. (Part 1: General requirements)

ISO 10218: Manipulating industrial robots -Safety.

etc.



Caution

Caution indicates a hazard with a low level of risk which, if not avoided, could result in minor or moderate injury.



Warning

Warning indicates a hazard with a medium level of risk which, if not avoided, could result in death or serious injury.



Danger

Danger indicates a hazard with a high level of risk which, if not avoided, will result in death or serious injury.

Warning

1. The compatibility of the product is the responsibility of the person who designs the equipment or decides its specifications.

Since the product specified here is used under various operating conditions, its compatibility with specific equipment must be decided by the person who designs the equipment or decides its specifications based on necessary analysis and test results.

The expected performance and safety assurance of the equipment will be the responsibility of the person who has determined its compatibility with the product.

This person should also continuously review all specifications of the product referring to its latest catalog information, with a view to giving due consideration to any possibility of equipment failure when configuring the equipment.

2. Only personnel with appropriate training should operate machinery and equipment.

The product specified here may become unsafe if handled incorrectly.

The assembly, operation and maintenance of machines or equipment including our products must be performed by an operator who is appropriately trained and experienced.

3. Do not service or attempt to remove product and machinery/equipment until safety is confirmed.

1. The inspection and maintenance of machinery/equipment should only be performed after measures to prevent falling or runaway of the driven objects have been confirmed.

2. When the product is to be removed, confirm that the safety measures as mentioned above are implemented and the power from any appropriate source is cut, and read and understand the specific product precautions of all relevant products carefully.

3. Before machinery/equipment is restarted, take measures to prevent unexpected operation and malfunction.

4. Contact SMC beforehand and take special consideration of safety measures if the product is to be used in any of the following conditions.

1. Conditions and environments outside of the given specifications, or use outdoors or in a place exposed to direct sunlight.

2. Installation on equipment in conjunction with atomic energy, railways, air navigation, space, shipping, vehicles, military, medical treatment, combustion and recreation, or equipment in contact with food and beverages, emergency stop circuits, clutch and brake circuits in press applications, safety equipment or other applications unsuitable for the standard specifications described in the product catalog.

3. An application which could have negative effects on people, property, or animals requiring special safety analysis.

4. Use in an interlock circuit, which requires the provision of double interlock for possible failure by using a mechanical protective function, and periodical checks to confirm proper operation.



Safety Instructions

Caution

1. The product is provided for use in manufacturing industries.

The product herein described is basically provided for peaceful use in manufacturing industries. If considering using the product in other industries, consult SMC beforehand and exchange specifications or a contract if necessary. If anything is unclear, contact your nearest sales branch.

Limited warranty and Disclaimer/Compliance Requirements

The product used is subject to the following "Limited warranty and Disclaimer" and "Compliance Requirements".

Read and accept them before using the product.

Limited warranty and Disclaimer

1. The warranty period of the product is 1 year in service or 1.5 years after the product is delivered, whichever is first.*2)

Also, the product may have specified durability, running distance or replacement parts. Please consult your nearest sales branch.

2. For any failure or damage reported within the warranty period which is clearly our responsibility, a replacement product or necessary parts will be provided.

This limited warranty applies only to our product independently, and not to any other damage incurred due to the failure of the product.

3. Prior to using SMC products, please read and understand the warranty terms and disclaimers noted in the specified catalog for the particular products.

***2) Vacuum pads are excluded from this 1 year warranty.**

A vacuum pad is a consumable part, so it is warranted for a year after it is delivered.

Also, even within the warranty period, the wear of a product due to the use of the vacuum pad or failure due to the deterioration of rubber material are not covered by the limited warranty.

Compliance Requirements

1. The use of SMC products with production equipment for the manufacture of weapons of mass destruction (WMD) or any other weapon is strictly prohibited.

2. The exports of SMC products or technology from one country to another are governed by the relevant security laws and regulation of the countries involved in the transaction. Prior to the shipment of a SMC product to another country, assure that all local rules governing that export are known and followed.

Operator

- ◆ This operation manual is intended for those who have knowledge of machinery using pneumatic equipment, and have sufficient knowledge of assembly, operation and maintenance of such equipment. Only those persons are allowed to perform assembly, operation and maintenance.
- ◆ Read and understand this operation manual carefully before assembling, operating or providing maintenance to the product.

■ Safety Instructions

Warning

- Do not disassemble, modify (including changing the printed circuit board) or repair.
An injury or failure can result.
- Do not operate the product outside of the specifications.
Do not use for flammable or harmful fluids.
Fire, malfunction, or damage to the product can result.
Verify the specifications before use.
- Do not operate in an atmosphere containing flammable or explosive gases.
Fire or an explosion can result.
This product is not designed to be explosion proof.
- If using the product in an interlocking circuit:
 - Provide a double interlocking system, for example a mechanical system.
 - Check the product regularly for proper operation.Otherwise malfunction can result, causing an accident.
- The following instructions must be followed during maintenance:
 - Turn off the power supply.
 - Stop the air supply, exhaust the residual pressure and verify that the air is released before performing maintenance work.Otherwise an injury can be caused.

Caution

- Do not touch terminals and printed circuit board inside the product.
Otherwise it can cause electric shock, malfunction or damage to the product can result.
- After maintenance is complete, perform appropriate functional inspections.
Stop operation if the equipment does not function properly.
Safety cannot be assured in the case of unexpected malfunction.
- Be sure to confirm the wiring condition.
This series, including this product, is not equipped with excessive current protection.
Therefore, incorrect wiring and or a short-circuited load could damage and or burn this product.

■ NOTE

- Follow the instructions given below when designing, selecting and handling your Auto switch.
 - The instructions on design and selection (installation, wiring, environment of use, adjustment, operation, maintenance and etc.) described below must also be followed.
 - Do not place two or more actuators close together.
When using more than two Auto switches mounted parallel with each other, keep 40 mm or more between actuator tubes to prevent influence (malfunction) due to magnetic interference. (Keep the allowable displacement for each Auto switch if specified)
 - Detection of a piston by Auto switch mounted in the middle part of a cylinder stroke depends on the speed of the piston. Satisfy the conditional equation below.
Where the maximum detectable piston speed = V (mm/s)
$$V \text{ (mm/s)} = \frac{\text{Travel of auto switch (mm)}}{\text{Change over time of load (ms)}} \times 1000$$
 - Reserve a space for maintenance.
Remember to leave space for maintenance when installing the product.

● Product handling

*Installation

- Follow the specified tightening torque. (0.05 to 0.10 Nm)
Excessive tightening torque can break the mounting screws, mounting bracket or Auto switch.
Insufficient tightening torque can displace the Auto switch from the original position.
(Refer to the installation manual)
- Connect frame-ground terminal (FG terminal) to the ground when using a switching power supply.
- Do not drop, hit or apply excessive shock (larger than 1000 m/s²) to the Auto switch.
Otherwise it can result in damage to the Auto switch causing failure or malfunction.

*Wiring

- Do not pull the lead wires.
Especially never lift actuator equipped with Auto switch by holding the lead wires.
It can result in damage to inside of Auto switch causing malfunction.
- Do not bend or apply tensile stress to lead wires repeatedly.
Wiring with repetitive bending stress or tensile stress can cause peel of a sheath.
If the lead wire can move, fix it near the body of the Auto switch.
A bend radius of about 40 to 80 mm is recommended. Contact us for the details.
- Connect wires and cables correctly.
Miswiring can break the Auto switch depending on the miswired circuit.
- Do not connect wires while the power is on.
Otherwise it can break the circuit inside the Auto switch causing malfunction.
- Do not lay wires or cables with power cable or high-voltage cable in the same wiring route.
Lay the wires to the Auto switch to a wire duct or in a protective tube other than those for power cables or high-voltage cables to prevent contamination with noise or induced surge voltage from power lines or high-voltage lines.
- Verify the insulation of wiring.
Poor insulation (interference with other circuit, poor insulation between terminals and etc.) can introduce excess voltage or current to the Auto switch causing damage.
- Keep wiring as short as possible to prevent contamination from noise and induced surge voltage.
Do not use a cable longer than 100 m.

*Environment

- Never use the product for a corrosive gas or liquid.
It can cause failure or malfunction.
- Do not use the product in a place where strong magnetic field exists.
It can cause a malfunction of the Auto switch, or demagnetization of a magnet inside actuator.
- Do not use the Auto switch in an environment where the Auto switch is always splashed with water drips.
It can cause poor insulation or malfunction due to swelling of a resin filled inside the Auto switch.
- Do not use the product in an atmosphere containing oils or chemicals.
Use of the Auto switch in an atmosphere containing various oils or chemicals such as coolant or detergent can result in giving bad influence (poor insulation, malfunction due to swelling of a resin filled inside the Auto switch, or hardening of lead wires) even if in a short operating period.
- Do not use the product in an atmosphere where steel dusts accumulate or magnetic bodies are gathered closely.
When an amount of steel chips or steel dusts such as sputters of welding accumulate around an actuator equipped with Auto switch, or magnetic bodies (those attracted by magnet) are gathered closely to the actuator, they can weaken a magnet inside the actuator causing inoperativeness of the Auto switch.
- Do not use the product in an environment where heat cycle exists.
Heat cycles other than ordinary change of the temperature can affect the inside of Auto switch.
- Do not use the Auto switch nearby a place where electric surges are generated.
Internal circuit elements of Auto switch can deteriorate or break when equipment generating a large surge (electromagnetic lifter, high frequency induction furnace, motor, etc.) is located near the Auto switch. Provide surge preventives, and avoid interference.
- Do not use a load generating surge voltage.
Use Auto switch equipped with surge absorber when a surge-generating load such as a relay or solenoid valve is driven directly.

*Adjustment and Operation

- Adjust an Auto switch in the middle of operating area and then fix it.
Adjust the position of Auto switch in a way that a piston stops at about the middle of operating area (where switch is in ON status).
Mounting the Auto switch close to the end of operating area can cause instability of operation.
Air grippers and rotary actuators have their own setting method. Follow their instructions.
- Turn the power on after connecting a load.
Otherwise it can cause excess current causing instantaneous breakage of the Auto switch.

*Maintenance

- Perform maintenance and check regularly.
Otherwise safety is not assured due to an unexpected malfunction or incorrect operation.
- Do not touch terminals or printed circuit board inside the switch while the power is on.
Otherwise it can cause in malfunction or damage to AUTO switch.

*Others

- Contact SMC for water-proof capability, endurance of wire bending or use at welding shop.
- Contact SMC when there is a problem of switch's ON/OFF positions (hysteresis).

Hysteresis

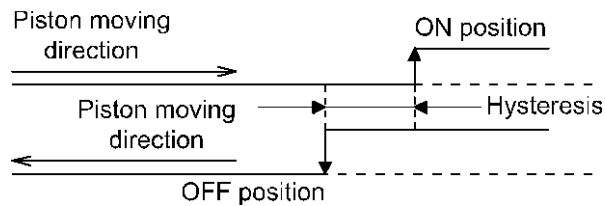

Model Indication and How to Order

D-M9 **A**

Output type ●

Symbol	Specification
N	3-wire, NPN
P	3-wire, PNP
B	2-wire

Electric entry ●

Symbol	Specification
NIL	In line
V	Perpendicular

● Lead wire length and termination

Symbol	Specification
NIL	500 mm (Half strip)
M	1000 mm (Half strip)
L	3000 mm (Half strip)
Z	5000 mm (Half strip)
SAPC	500 mm (M8 3-pin pre-wire)
SBPC	500 mm (M8 4-pin pre-wire)
SDPC	500 mm (M12 4-pin pre-wire)
MAPC	1000 mm (M8 3-pin pre-wire)
MBPC	1000 mm (M8 4-pin pre-wire)
MDPC	1000 mm (M12 4-pin pre-wire)

Summary of Product parts

•D-M9BA/M9NA/M9PA

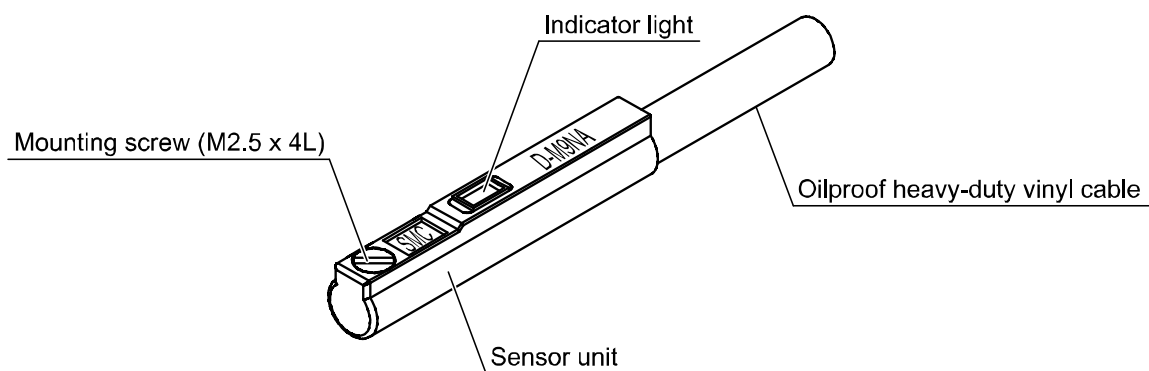

•D-M9BAV/M9NAV/M9PAV

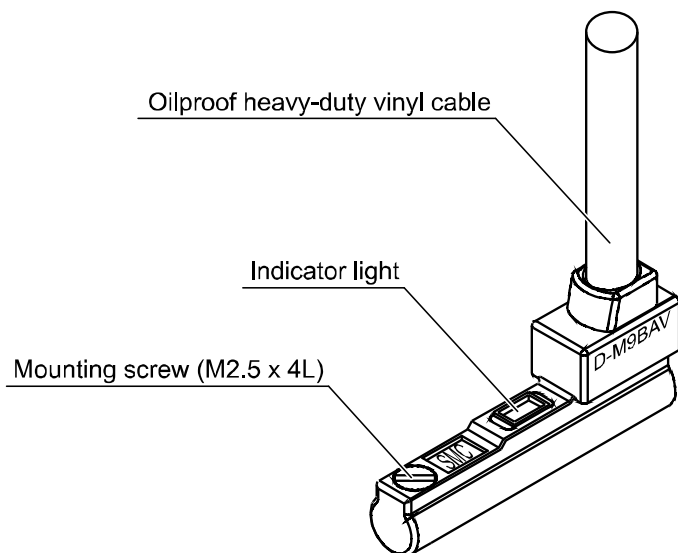

■ Definition and terminology

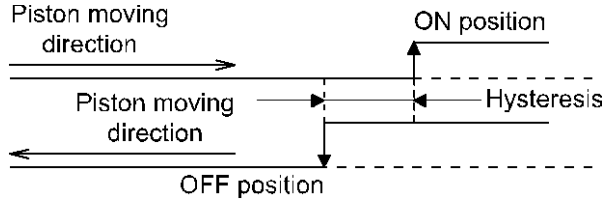
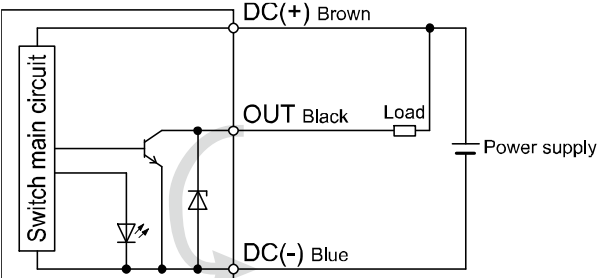
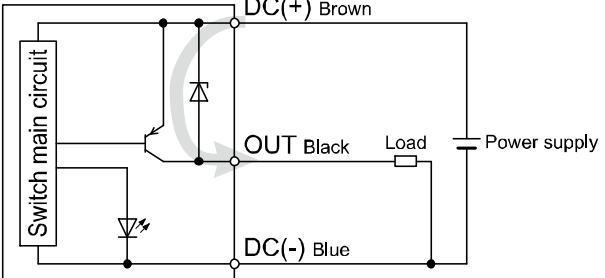
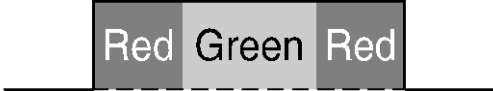
Term	Meaning and definition
Hysteresis	<p>The difference between the points when the Auto switch turns on and off, which is provided to prevent chattering.</p> 
Most sensitive position	<p>The center position of the sensor unit (which gets the strongest reaction of the sensor unit), which means the center position of an operating range as well.</p>
Sequence controller (PLC)	<p>The device to perform sequence control, which performs controlling such as receipt of inputs from the Auto switch along with programming and sending of the output to other machines.</p>
Internal voltage drop	<p>The voltage applied between the COM and signal line when the Auto switch turns on.</p>
Current leakage	<p>The current flowing to the load when the Auto switch turns off.</p>
Load current	<p>The current flowing to the load when the Auto switch turns on.</p>
Solid state auto switch	<p>Auto switch which generates on and off outputs with or without mechanical contact such as a transistor.</p>
Reed auto switch	<p>Auto switch which generates on and off outputs with a mechanical contact.</p>
2-wire auto switch	<p>Auto switch which has only signal line and COM line.</p>
NPN output	<p>Auto switch which sinks current from the signal line when turning on.</p> 
PNP output	<p>Auto switch which sources current from the signal line when turning on.</p> 
2-color indication	<p>A type of indicating methods which lights up the red LED light up when the Auto switch comes to the operating position, and lights up the green LED when the Auto switch comes to the optimum operating position.</p> 

Mounting and Installation

■ Installation

When mounting the Auto switch to actuator it should be done with clamp for actuator.

"How to mount" depends on actuator type and tube I.D. Please refer the actuator catalogue.

When the Auto switch is mounted newly, please prepare the clamp for actuator after confirms that the actuator built in magnet.

• Proper tightening torque

Use a watchmaker driver whose grip diameter is 5 to 6 mm when tightening the mounting screw.

M2.5 mount screw tightening torque range shall be 0.05 to 0.10 Nm (0.5 to 1.0 kgf•cm)

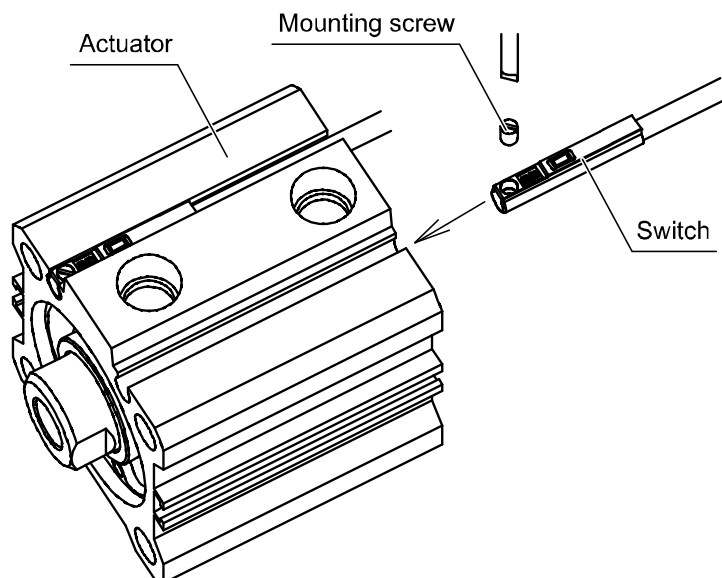

• Setting the detecting position

Set the actuator at the stroke end. Set the switch in the area to where the auto switch red lamp light.

(Detecting actuator end)

Based on A and B dimensions in the actuator catalogue, set the switch.

For actual installation works, perform adjustment with checking the operating conditions of the Auto switch.

Air grippers and rotary actuators have their own setting method. Follow their instructions.

■ Circuit diagram

●D-M9NA(V)

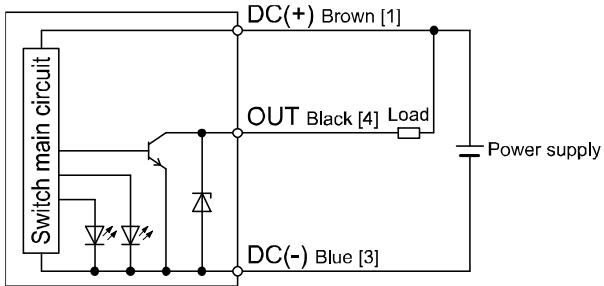

●D-M9PA(V)

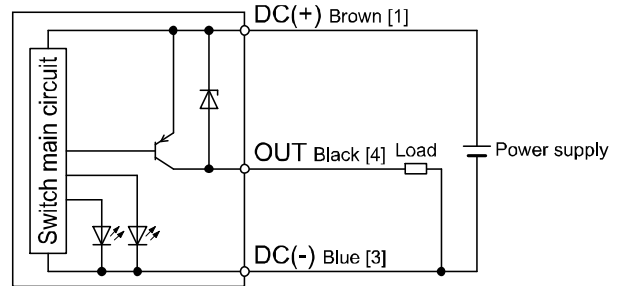

●D-M9BA(V) (Sink input mode)

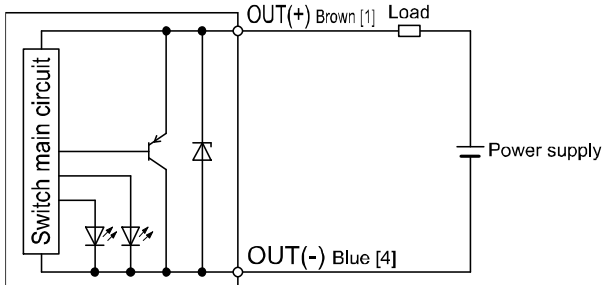

●D-M9BA(V) (Source input mode)

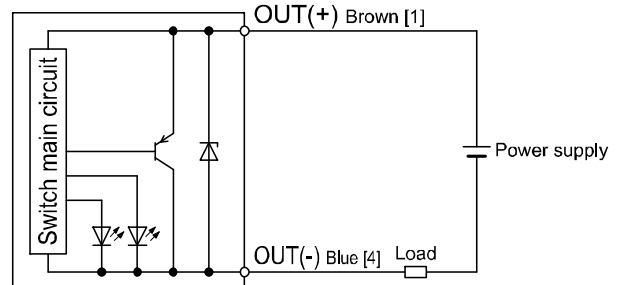

*: The number marked on each lead wire color shows the pin number of pre-wired connector.

Troubleshooting

When the auto switch falls in operation failure, identify the trouble with the following flow chart. A failure of the auto switch might depend on operating environment (application etc.) and needs to be given a measure by contacting to us separately.

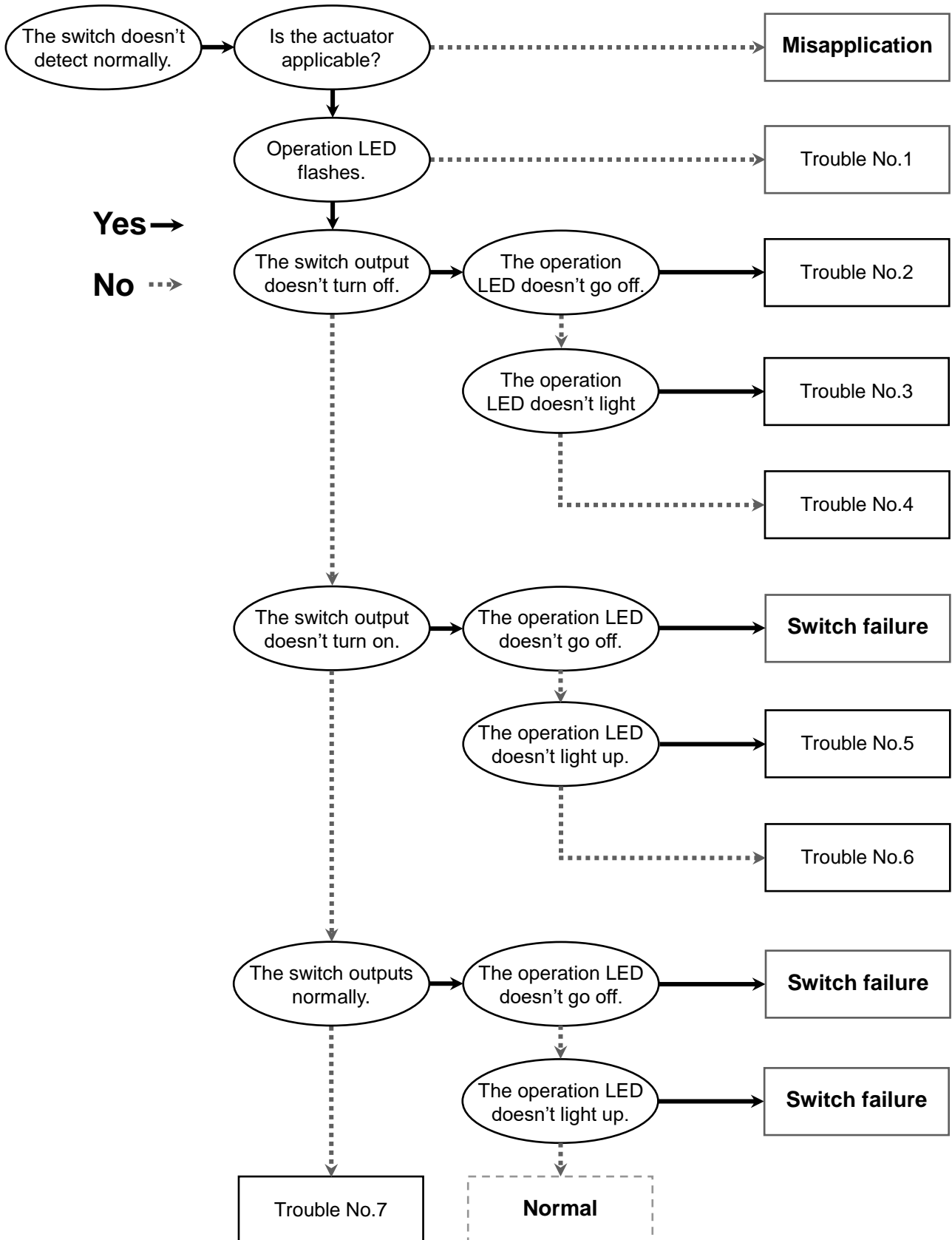

•Cross-reference for troubleshooting

Reference No.	Problem	Possible cause	Investigation method	Countermeasure
1	Output ON and OFF is displayed in turn	Wiring failure	Check that the load is connected.	Correct wiring. (Refer to "Circuit diagram" on page 12.)
		Not match with load specification	Check if load specification satisfy the formula below. Load current ≤ 40 mA	Change to a load which satisfies the formula.
		Lead wire disconnection	Presence of repeated bending stress to one point of the lead wire. (Bend radius/Tensile force to lead wire)	Correct wiring. (Correct tensile force/increase bend radius)
2	Output stays ON Display stays ON	Malfunction due to turbulence magnetic field	Influence of the magnetic field of adjacent cylinder.	Use magnetic shield between cylinders.
		Incorrect setting (mounting) position *: Short stroke	Check if the condition is as below. Switch operation range. > Piston stroke	Displace the switch set position from the operation range center.
3	Output stays ON Display stays OFF	Wiring failure (2-wire type)	Check if the switch wiring connection is reversed (Brown/Blue).	Correct wiring. (Refer to "Circuit diagram" on page 12.)
		Switch failure (3-wire type)		Replace the switch.
4	Output stays ON Display is normal	Not match with load specification (2-wire type)	Check if load specification satisfy the formula below. Load ON voltage > (Switch leak current x n) x Load resistance or load OFF current > (Switch leak current x n) n: Number of switch connected in parallel	Change to 3-wire type or reed Auto switch. Reduce the number of switch connected in parallel.
		Wiring failure (3-wire type)	Check reversed connection of the switch wiring (Black/Blue).	Correct wiring. (Refer to "Circuit diagram" on page 12.)

Reference No.	Problem	Possible cause	Investigation method	Countermeasure
5	Output stays OFF Display stays OFF	Abnormal power source	Check the source voltage. (Zero or very low)	Set the source voltage to specified voltage. (Refer to "Specifications (power voltage and load voltage)" on page 17.)
		Wiring failure	Voltage applied to switch (load voltage).	Correct wiring. (Refer to "Circuit diagram" on page 12.)
		Incorrect setting (mounting) position	Check if detection is made close to the operation range limit.	Correct the position. (Center of operation range)
		Set position displacement	Loose set bracket or set screw.	Fix at the right position with right torque. Tightening torque: 0.05 to 0.10 Nm
		Stop position displacement of the piston	Check if the stroke stop position is Inconsistent.	Stabilize stop position. (Correction of displacement/cushion)
		Decrease of Detected magnetic field (demagnetization)	Presence of magnetic field generating source around the cylinder. (Electric welding machine conductor/ Strong magnet)	Use the shield between magnetic field generating source and cylinder.
			Influence of magnetic field of adjacent cylinder (20 mm or less).	Keeps cylinder away (40 mm or more). Use magnetic shielding.
			Presence of magnetic material (chip) piled up on the cylinder.	Remove piled up magnetic material.
Lead wire disconnected	Presence of repeated bending stress to one point of the lead wire. (Bend radius/Tensile force to lead wire)	Correct wiring. (Correct tensile force/increase bend radius)		
6	Output stays OFF Display is normal	Not match with load specification (2-wire type)	Check if load specification satisfy the formula below. Load ON voltage < Load voltage – (Switch internal voltage drop x n) n: Number of switch connected in serial	Change to 3-wire type or reed Auto switch. Reduce the number of switch connected in serial.
		Wiring failure (Output line) (3-wire type)	Connect condition (connector contact pin / crimp terminal).	Correct wiring. (Re-wiring the connecting part)
		Disconnection of lead wire (black) (3-wire type)	Presence of repeated bending stress to one point of the lead wire. (Bend radius / Tensile force to lead wire)	Correct wiring. (Correct tensile force/increase bend radius)

Reference No.	Problem	Possible cause	Investigation method	Countermeasure
7	Unstable operation (Chattering)	Incorrect setting (mounting) position	Check if detection is made around the limit of operation range.	Correct the position. (center of the operation range.)
		Set position displacement	Loose set bracket or set screw.	Fix at the right position with right torque. Tightening torque: 0.05 to 0.10 Nm
		Wiring failure	Condition of connecting part (connector contact pin/crimp terminal).	Correct wiring. (Re-wiring of connecting part)
		Lead wire disconnection	Presence of repeated bending stress to one point of the lead wire. (Bend radius/Tensile force to lead wire)	Correct wiring. (Correct tensile force/increase bend radius)
		Malfunction due to turbulence magnetic field	Presence of magnetic field generating source around the cylinder. (Cylinder, electric welding machine conductor, motor, magnet etc.)	Use the shield between magnetic field generating source and cylinder. Keep the cylinder away from magnetic field generating source.
	Multiple point operation	Malfunction due to turbulence magnetic field	Influence of the magnetic field of adjacent cylinder.	Use magnetic shield between Cylinders.
	Load does not operate	Detect the intermediate position of the stroke	Check if piston speed satisfy the formula below. Load operation time [s] < Switch operation time [mm] /piston speed [mm/s]	Reduce the piston speed until the formula is satisfied

Specification

■ Specifications

Switch part no.	D-M9NA	D-M9NAV	D-M9PA	D-M9PAV	D-M9BA	D-M9BAV
Lead wire orientation	In line	Perpendicular	In line	Perpendicular	In line	Perpendicular
Wiring	3-wire			2-wire		
Output	NPN		PNP		-	
Applicable load	IC circuit/Relay/PLC			24 VDC Relay/PLC		
Power supply voltage	5/12/24 VDC (4.5 to 28 VDC)			-		
Current consumption	10 mA or less			-		
Load voltage	28 VDC or less		-		24 VDC (10 to 28 VDC)	
Load current	40 mA or less			2.5 to 40 mA		
Internal voltage drop	0.8 V or less at load current of 10 mA (2 V or less at load current of 40 mA)			4 V or less		
Current leakage	100 μ A or less at 24 VDC			0.8 mA or less		
Indication light	Operating position: The red LED lights up. Optimum operating position: The green LED lights up.					
Standard	CE marked (EMC directive, RoHS directive)					

● Oilproof heavy-duty lead wire specifications

Switch part no.	D-M9NA#	D-M9NAV#	D-M9PA#	D-M9PAV#	D-M9BA#	D-M9BAV#
Sheath	Outside diameter (mm)	2.6				
	Wires	3-wire (Brown, Blue, Black)			2-wire (Brown, Blue)	
Insulator	Outside diameter (mm)	0.88				
	Cross section (mm ²)	0.13				
Conductor	Wire diameter (mm)	0.05				
	Minimum bending radius (mm) (Reference value)	17				

■ Dimensions

●D-M9BA/M9NA/M9PA

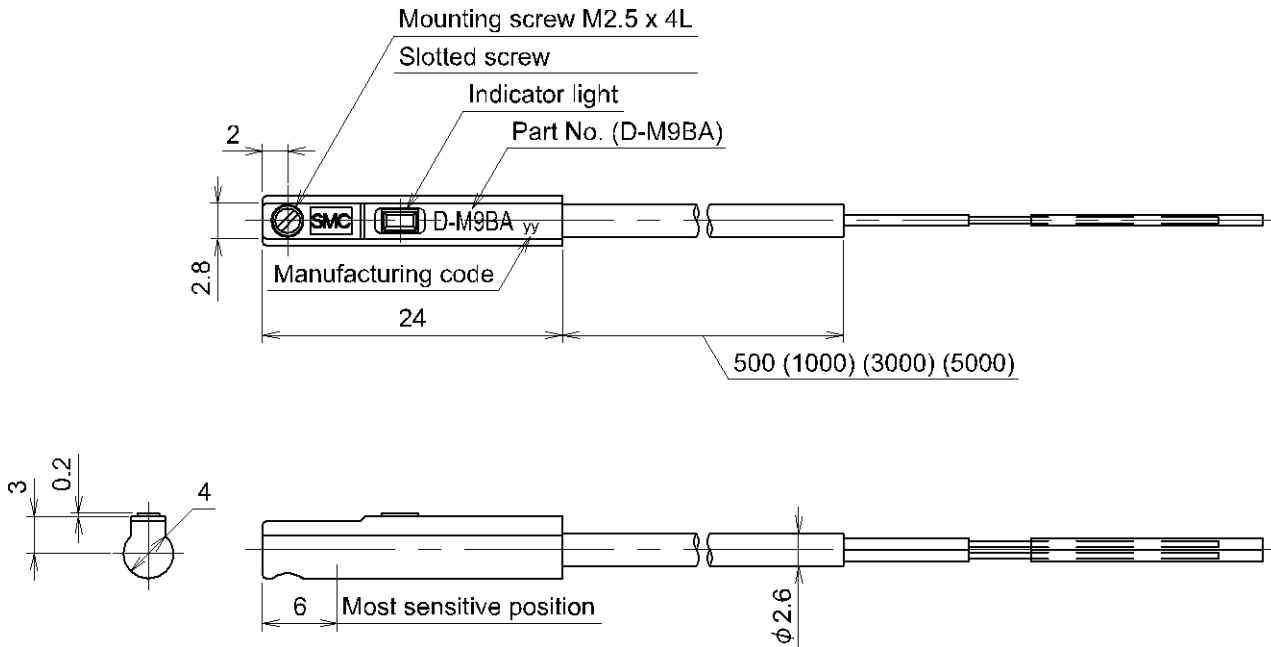

●D-M9BAV/M9NAV/M9PAV

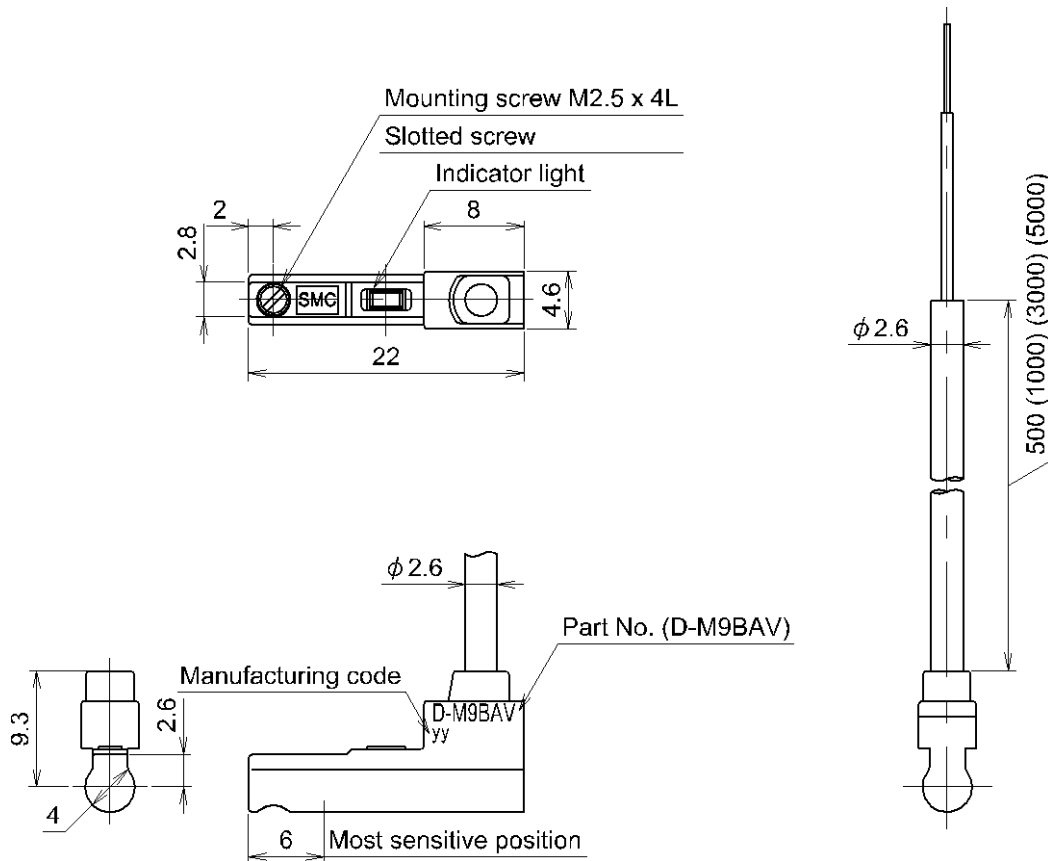

Revision history

- A: Modify the contents.
- B: Limited warranty and Disclaimer are added.
- C: Contents revised in several places.
[August 2016]
- D: Contents revised in several places.
[August 2018]
- E: Contents revised in several places [June 2019]
- F: Contents revised in several places [April 2020]
- G: Modified errors in text [October 2020]

SMC Corporation

4-14-1, Sotokanda, Chiyoda-ku, Tokyo 101-0021 JAPAN

Tel: + 81 3 5207 8249 Fax: +81 3 5298 5362

URL <https://www.smcworld.com>

Note: Specifications are subject to change without prior notice and any obligation on the part of the manufacturer.

© 2006-2020 SMC Corporation All Rights Reserved.

