

## MGP-AZ, Compact Guide Cylinder, Air Cushion MGPM50TF-100AZ

### Datasheet

At SMC we have 'rolled' out an upgrade of our MGP Series guide cylinder, which is now smaller and boasts new features. The new MGP-Z is testament to our commitment to invest in ongoing research and development to refine and improve the performance and functionality of SMC products. The MGP-Z is up to 17% lighter and offers space savings thanks to shorter guide rods, without impacting on the variety of functions, robustness and quality performance of the original series. Another recent key development feature is that round auto switches can now be fitted directly onto the MGP-Z cylinder, removing the need for mounting brackets and reducing labour costs. The common issue of incorrectly positioned auto switches is also mitigated when using SMC's two colour indication solid state auto switch, D-M9\*W. The MGP-Z has many standard feature options including three types of bearings, four mount designs, piping from two directions and offers cooper and fluorine free versions. Suitable for many industries including General Automation and Car, it has several applications including smooth pusher and lifter, lateral load by acting as a stopper where shock is applied, or minimising plate displacement.



Double-acting, single-rod cylinder

### Standard specifications

Bearing Type	M (Slide Bearing)
Bore Size	Ø50 mm
Port Thread Type	TF [G]
Stroke	100 mm
Auto Switch	No Switch
Lead Wire or Prewired Connector	0.5m [Or None in the Case of No Switch]
Number	2 pcs. [Or None in the Case of No Switch]
Made to Order	None
Pressure medium	Air
Maximum temperature of pressure medium	60 °C
Minimum temperature of pressure medium	-10 °C (No freezing)
Maximum operating pressure	1.0 MPa
Minimum operating pressure	0.12 MPa

Proof pressure	1.5 MPa
Maximum ambient temperature	60 °C
Maximum ambient temperature with magnet	-10 °C (No freezing)
Numero of pneumatic connections	4 pcs.
Pneumatic input connection	G 1/4
Pneumatic output connection	G 1/4
Mode of operation of drive	Double acting
Theoretical cylinder force, advance stroke (at 0.5 MPa)	982 N
Theoretical cylinder force, return stroke (at 0.5 MPa)	825 N
Maximum piston speed	500 mm/s
Type of cushioning	Air cushion on both ends (Without bumper)
Non-rotating accuracy of plate	± 0.04 °
Weight	5.320 Kg

## Dimensions

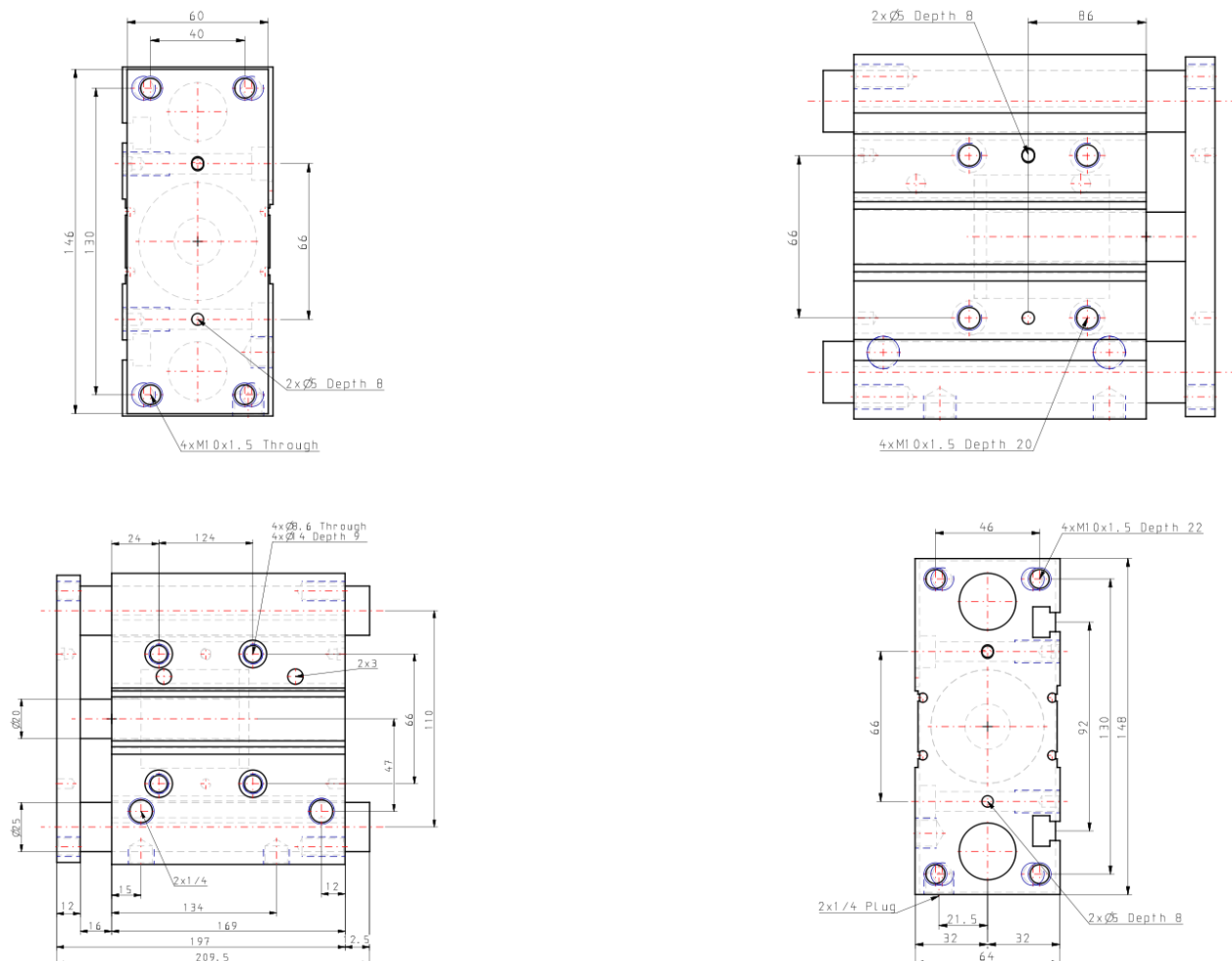

# Constructions

## MGPM

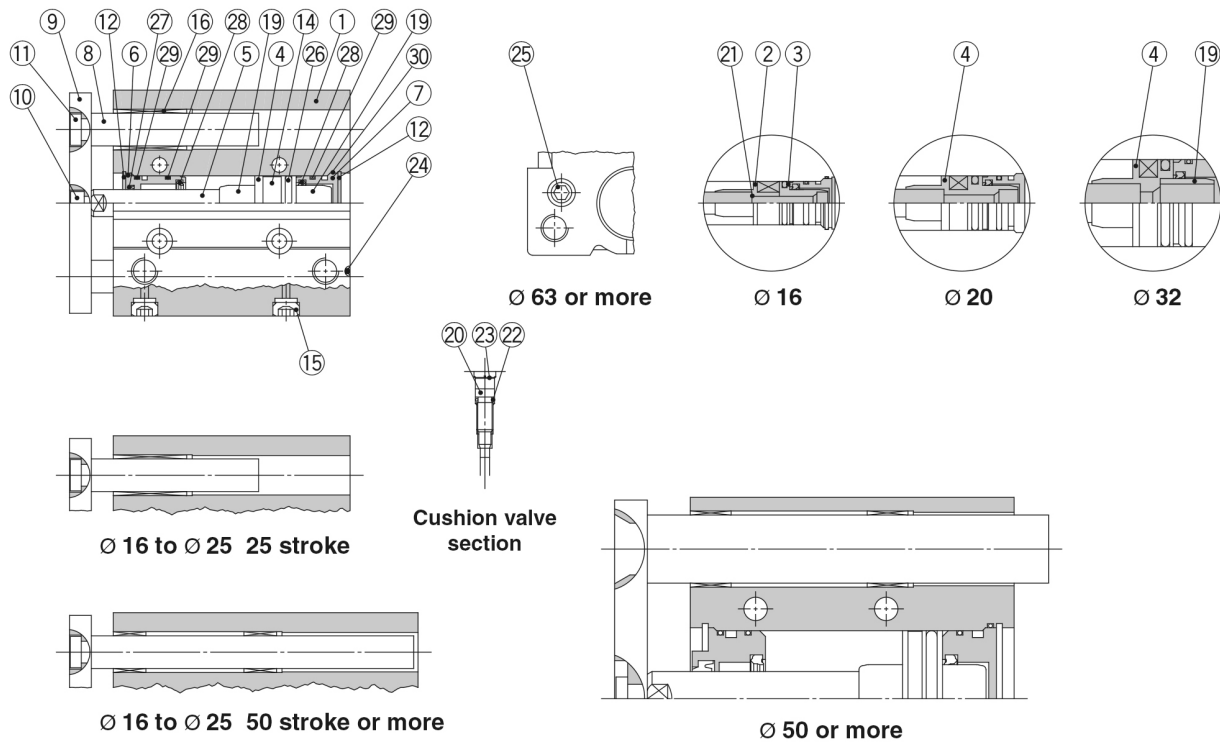

### Component Parts

No.	Description	Material	Note
1	Body	Aluminium alloy	Hard anodised
2	Piston A	Aluminium alloy	Ø 16
3	Piston B	Aluminium alloy	Ø 16
4	Piston	Aluminium alloy	Ø 20 to Ø 100
5	Piston rod	Stainless steel	Ø 16 to Ø 25
		Carbon steel	Ø 32 to Ø 100   Hard chrome plating
6	Collar	Aluminium alloy	Chromated
7	Head cover	Aluminium alloy	Chromated
8	Guide rod	Carbon steel	Hard chrome plating
9	Plate	Carbon steel	Nickel plating
10	Plate mounting bolt	Carbon steel	Nickel plating
11	Guide bolt	Carbon steel	Nickel plating
12	Retaining ring	Carbon tool steel	Phosphate coated
13	Retaining ring	Carbon tool steel	Phosphate coated
14	Magnet	—	
15	Plug	Carbon steel	Ø 16
	Hexagon socket head plug		Ø 20 to Ø 100
16	Slide bearing	Bearing alloy	
17	Ball bushing	—	
18	Spacer	Aluminium alloy	
19	Cushion ring	Aluminium alloy	Ø 25 to Ø 100   Anodised
20	Cushion valve		Ø 16 to Ø 32   Electroless nickel plating
	Cushion needle		Ø 50 to Ø 100   Chromated
			Ø 40 only   Electroless nickel plating

\*: A felt is not installed on the slide bearing.

### Component Parts

No.	Description	Material	Note
21	Gasket	NBR	Ø 16
22	Gasket	NBR	
23	Retaining ring	Carbon tool steel	Ø 50, Ø 63   Phosphate coated
24	Steel ball	Carbon steel	Ø 16 to Ø 50
25	Plug	Carbon steel	Ø 63 to Ø 100   Nickel plating
26*	Piston seal	NBR	
27*	Rod seal	NBR	
28*	Cushion seal	Urethane	
29*	Gasket A	NBR	
30*	Gasket B	NBR	

### Replacement Parts/Seal Kit

Bore size [mm]	Kit no.	Contents	Bore size [mm]	Kit no.	Contents
16	MGP16-AZ-PS	Set of nos. above 26, 27, 28, 29, 30	50	MGP50-AZ-PS	Set of nos. above 26, 27, 28, 29, 30
20	MGP20-AZ-PS		63	MGP63-AZ-PS	
25	MGP25-AZ-PS		80	MGP80-AZ-PS	
32	MGP32-AZ-PS		100	MGP100-AZ-PS	
40	MGP40-AZ-PS				

\*: Seal kit includes 26 to 30. Order the seal kit, based on each bore size.

\*: Since the seal kit does not include a grease pack, order it separately.

**Grease pack part no.: GR-S-010 (10 g)**

## Additional information

Catalogue

[MGP-Z-Dd\\_EU.pdf#page=30](#)